











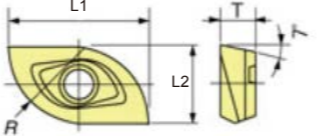

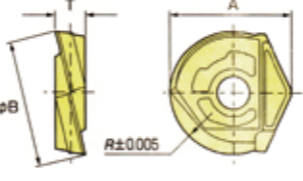
(A) 銑刀
ENDMILLS
(B) 鑽頭
DRILLS
(C) 絞刀
REAMERS
(D) 絲攻
TAPS
(E) 刀桿/刀盤
MILLING CUTTERS
(F) 刀片
INSERTS

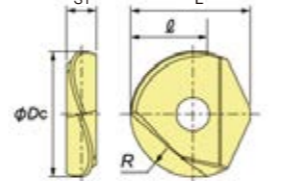

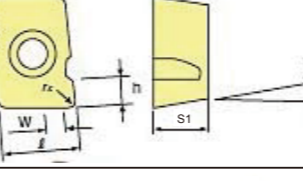

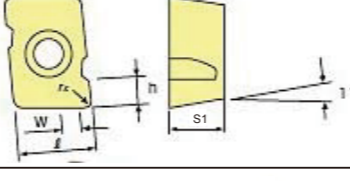

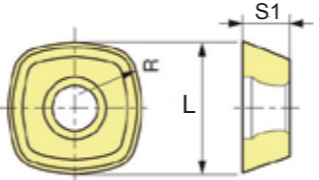

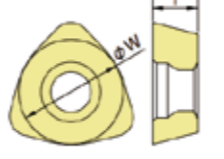
(A) 銑刀
ENDMILLS
(B) 鑽頭
DRILLS
(C) 絞刀
REAMERS
(D) 絲攻
TAPS
(E) 刀桿/刀盤
MILLING CUTTERS
(F) 刀片
INSERTS

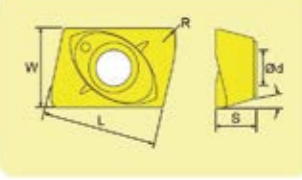
| 被切削材 | 塗層 Coating | | | | 尺寸(mm) | | | | 刀片形狀 Insert Shape |
|-----------------------------|--------------------|---------|---------|---------|--------|-------|------|----|-------------------|
| | VMH4105 | VMM45TF | VMH4120 | VMH4020 | L1 | L2 | S1 | θ | |
| P 鋼材 | ● | ● | ● | ● | | | | | |
| M 不鏽鋼 | ● | ● | ● | ● | | | | | |
| K 鑄鐵 | ● | ● | ● | ● | | | | | |
| N 非鐵金屬 | ● | ● | ● | ● | | | | | |
| S 難切削材質 | ● | ● | ● | ● | | | | | |
| H 加工硬料 | ● | ● | ● | ● | | | | | |
| 刀片外觀 Insert exterior | 代號 Codename | | | | | | | | |
| | AOMT1236... | | | | 12 | 6.6 | 3.6 | 11 | |
| | APET1202... | | | | 12.7 | 7.938 | 2.5 | 11 | |
| | APMT1135... | ● | | | 11 | 6.35 | 3.5 | 11 | |
| | APGT1604... | | | | 16.5 | 9.525 | 4.76 | 11 | |
| | JOMW06T2...FT | ● | | | 6.35 | 2.78 | 13 | | |
| | JOMW0803...FT | ● | | | 8 | 3.18 | 13 | | |
| | JDMT09T3...FT | ● | | | 9.525 | 3.97 | 15 | | |
| | JDMT1204...FT | ● | | | 12 | 4.76 | 15 | | |
| | JOMW06T2...JM | ● | | | 6.35 | 2.78 | 13 | | |
| | JOMW0803...JM | ● | | | 8 | 3.18 | 13 | | |
| | JDMT09T3...JM | ● | | | 9.525 | 3.97 | 15 | | |
| | JDMT1204...JM | ● | | | 12 | 4.76 | 15 | | |

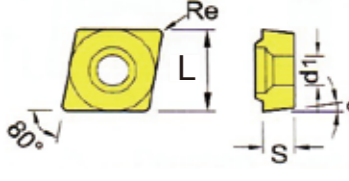
| 被切削材 | 塗層 Coating | | | | 尺寸(mm) | | | | 刀片形狀 Insert Shape |
|-----------------------------|--------------------|---------|---------|---------|--------|------|------|----|-------------------|
| | VMH4105 | VMM45TF | VMH4120 | VMH4020 | L1 | L2 | S1 | θ | |
| P 鋼材 | ● | ● | ● | ● | | | | | |
| M 不鏽鋼 | ● | ● | ● | ● | | | | | |
| K 鑄鐵 | ● | ● | ● | ● | | | | | |
| N 非鐵金屬 | ● | ● | ● | ● | | | | | |
| S 難切削材質 | ● | ● | ● | ● | | | | | |
| H 加工硬料 | ● | ● | ● | ● | | | | | |
| 刀片外觀 Insert exterior | 代號 Codename | | | | | | | | |
| | QOMT0830... | | ● | | 8.4 | 5.5 | 3 | | |
| | QOMT1035... | | ● | | 10.6 | 7 | 3.5 | | |
| | RPMT08T2... | | ● | | 8 | | 2.78 | 11 | |
| | RPMT10T3... | | ● | | 10 | | 3.97 | 11 | |
| | RDMW0517... | ● | ● | | 5 | | 1.70 | 15 | |
| | RDMW0620... | ● | ● | | 6 | | 1.99 | 15 | |
| | RDMW0724... | ● | ● | | 7 | | 2.38 | 15 | |
| | SEMT13T3... | | ● | | 13.4 | 13.4 | 3.97 | 20 | |
| | SRFT10 | | ● | | 8.5 | | 10 | | |
| | SRFT12 | | ● | | 10 | | 12 | | |
| | EPNW0603... | ● | ● | ● | 10 | 6.35 | 3.18 | 11 | |
| | EPNW12T3... | ● | ● | ● | 12 | 10 | 3.97 | 11 | |
| | EPMT0603... | ● | ● | ● | 10 | 6.35 | 3.18 | 11 | |
| | EPMT0603... | ● | ● | ● | 12 | 10 | 3.97 | 11 | |

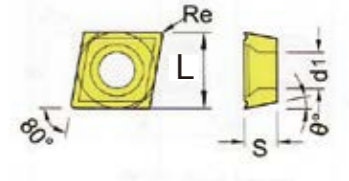
(A) 銑刀
ENDMILLS
(B) 鑽頭
DRILLS
(C) 絞刀
REAMERS
(D) 絲攻
TAPS
(E) 刀桿/刀盤
MILLING CUTTERS
(F) 刀片
INSERTS

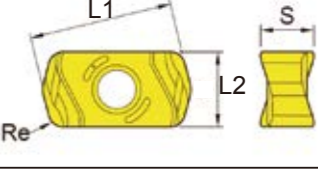

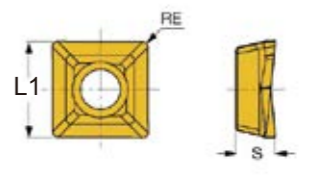
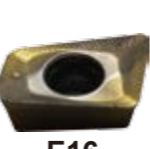
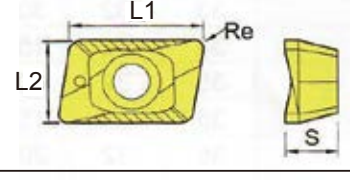





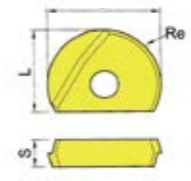

| 被切削材 | 塗層 Coating | | | | | | 尺寸(mm) | | | | 刀片形狀 Insert Shape |
|---|-------------|-------|------|--------|---------|--------|--------|-----|------|----|---|
| | P 鋼材 | M 不鏽鋼 | K 鑄鐵 | N 非鐵金屬 | S 難切削材質 | H 加工硬料 | L1 | L2 | S1 | θ | |
|  | ZCET080CE | | | ● | ● | | 15.6 | 7.9 | 3.97 | 7 |  |
| | ZCET100CE | | | ● | ● | | 18.3 | 10 | 4.74 | 7 | |
| | ZCEW080CE | | | ● | ● | | 15.6 | 7.9 | 3.97 | 7 | |
| | ZCEW100CE | | | ● | ● | | 18.3 | 10 | 4.74 | 7 | |
|  | ZDFG060-WF | | | | | | 5 | 6 | 2 | 11 |  |
| | ZDFG080-WF | | | | | | 9.7 | 8 | 2.1 | 11 | |
| | ZDFG100-WF | | | | | | 12.1 | 10 | 2.7 | 11 | |
| | ZDFG060-WH | | | | | | 5 | 6 | 2 | 11 | |
|  | ZDFG080-WH | | | | | | 9.7 | 8 | 2.1 | 11 |  |
| | ZDFG100-WH | | | | | | 12.1 | 10 | 2.7 | 11 | |
| | ZDFG06N-WF | | | | | | 5 | 6 | 2 | 15 | |
| | ZDFG080-WF | | | | | | 9.7 | 8 | 2.1 | 15 | |
|  | ZDFG100-WF | | | | | | 12.1 | 10 | 2.7 | 15 |  |
| | ZDFG06N-WH | | | | | | 5 | 6 | 2 | 15 | |
| | ZDFG080-WH | | | | | | 9.7 | 8 | 2.1 | 15 | |
| | ZDFG100-WH | | | | | | 12.1 | 10 | 2.7 | 15 | |
|  | MPHW0603... | ● | | | | | 6.35 | | 3.18 | 11 |  |
| | | | | ● | ● | | | | | | |
|  | SDNW1505... | ● | | | | | 15.875 | | 5.56 | 15 |  |
| | SDMT1505... | ● | | | | | 15.875 | | 5.56 | 15 | |
| | SDEW1505... | ● | | | | | 15.875 | | 5.56 | 15 | |
|  | WDNW09T3... | ● | | | | | 9.525 | | 3.97 | 7 |  |
| | WDNW1204... | ● | | | | | 12 | | 4.76 | 7 | |

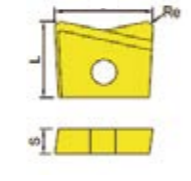

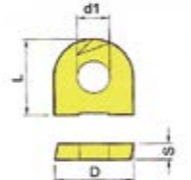

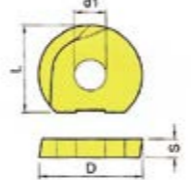

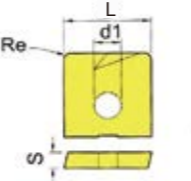

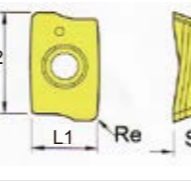

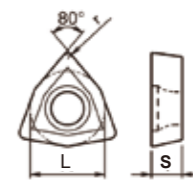
| 被切削材 | 塗層 Coating | | | | | | 尺寸(mm) | | | | 刀片形狀 Insert Shape |
|---|-------------|-------|------|--------|---------|--------|--------|------|------|----|---|
| | P 鋼材 | M 不鏽鋼 | K 鑄鐵 | N 非鐵金屬 | S 難切削材質 | H 加工硬料 | L1 | L2 | S1 | θ | |
|  | JDMT070202 | | | ● | ● | | 6.4 | 4.3 | 2.45 | |  |
| | JDMT070204 | | | ● | ● | | 6.4 | 4.3 | 2.45 | | |
| | JDMT070208 | | | ● | ● | | 6.4 | 4.3 | 2.45 | | |
|  | CCMT0602... | | | | | | 6.35 | | 2.38 | 7 |  |
| | CPMT0903... | | | | | | 9.525 | | 3.18 | 11 | |
| | CPMT1204... | | | | | | 12.7 | | 4.76 | 11 | |
|  | CPMT0802... | | | | | | 7.94 | | 2.38 | 11 |  |
| | CPMT0902... | | | | | | 9.525 | | 3.18 | 11 | |
| | CPMT1203... | | | | | | 12.7 | | 4.76 | 11 | |
|  | LNMU0303... | | | | | | 11.59 | 6 | 3.18 | |  |
| | | | | | | | | | | | |
|  | XOET0602... | | | | | | 6.94 | 4.09 | 2.45 | 15 |  |
| | XOMT0602... | | | | | | 6.94 | 4.09 | 2.45 | 15 | |
|  | XOMT0903... | | | | | | 9 | 6.4 | 3.65 | 15 |  |
| | XOMT12T4... | | | | | | 9.3 | 6.9 | 3.83 | 15 | |
| | XOMT10T3... | | | | | | 11.6 | 8.2 | 5.07 | 15 | |

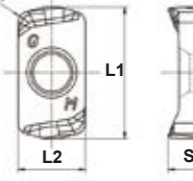
(A) 銑刀
ENDMILLS
(B) 鑽頭
DRILLS
(C) 絞刀
REAMERS
(D) 絲攻
TAPS
(E) 刀桿/刀盤
MILLING CUTTERS
(F) 刀片
INSERTS

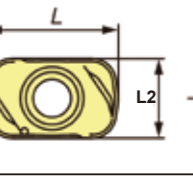
(A) 銑刀
ENDMILLS
(B) 鑽頭
DRILLS
(C) 絞刀
REAMERS
(D) 絲攻
TAPS
(E) 刀桿/刀盤
MILLING CUTTERS
(F) 刀片
INSERTS

(A) 銑刀
ENDMILLS
(B) 鑽頭
DRILLS
(C) 絞刀
REAMERS
(D) 絲攻
TAPS
(E) 刀桿/刀盤
MILLING CUTTERS
(F) 刀片
INSERTS

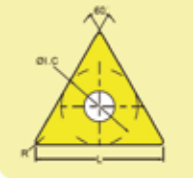
| 被切削材 Insert exterior | 代號 Codename | 塗層 Coating | | | | 尺寸(mm) | | | | 刀片形狀 Insert Shape |
|--|-------------------|---------------|---------|---------|---------|--------|------|------|---|----------------------|
| | | VMH4105 | VMM45TF | VMH4120 | VMH4020 | L1 | L2 | S1 | θ | |
| | | | | | | | | | | |
|  E32 | (BNM/SRHT)PPH-080 | | | | | 8 | 2.4 | 7 |  | |
| | 100 | | | | 10 | 2.6 | 8.5 | | | |
| | 120 | | | | 12 | 3 | 10 | | | |
| | 160 | | | | 16 | 4 | 12 | | | |
| | 200 | | | | 20 | 5 | 15 | | | |
| | 250 | | | | 25 | 6 | 19 | | | |
|  E32 | PPHT-120 | | | | | 12 | 10 | 3 |  | |
| | PPHT-160 | | | | | 16 | 12 | 4 | | |
| | PPHT-200 | | | | | 20 | 15 | 5 | | |
| | SUFT12R10 | | | | | 12 | 10 | 3 | | |
| | SUFT16R10 | | | | | 16 | 12 | 4 | | |
| SUFT20R15 | | | | | 20 | 15 | 5 | | | |
|  E30 | P3202-D08 | | | | | 8 | 9.5 | 2 |  | |
| | P3202-D10 | | | | | 10 | 11.5 | 2.5 | | |
| | P3202-D12 | | | | | 12 | 12 | 2.5 | | |
|  E30 | P3020-D16 | | | | | 16 | 14 | 3 |  | |
| | P3020-D20 | | | | | 20 | 16 | 3 | | |
| | P3020-D25 | | | | | 25 | 21.5 | 4 | | |
| | P3020-D30 | | | | | 30 | 25.5 | 5 | | |
|  E30 | WPV12-N-SLST | | | | | 12 | | 2.5 |  | |
| | WPV16-N-SLST | | | | | 16 | | 3 | | |
| | WPV20-N-SLST | | | | | 20 | | 3 | | |
| | WPV25-N-SLST | | | | | 25 | | 4 | | |
|  E18 | R390-11T308 | | | | | 11 | 6.8 | 3.59 |  | |
| | R390-170408 | | | | | 17 | 9.6 | 4.76 | | |

| 被切削材 Insert exterior | 代號 Codename | 塗層 Coating | | | | 尺寸(mm) | | | | 刀片形狀 Insert Shape |
|--|----------------|---------------|---------|---------|---------|--------|-----|------|---|----------------------|
| | | VMH4105 | VMM45TF | VMH4120 | VMH4020 | L1 | L2 | S1 | θ | |
| | | | | | | | | | | |
|  E43 | WCMX030208 | | | | | 5.56 | | 2.38 |  | |
| | WCMX040208 | | | | | 6.35 | | 2.38 | | |
| | WCMX050308 | | | | | 7.94 | | 3.18 | | |
| | WCMX06T308 | | | | | 9.525 | | 3.18 | | |
| | WCMX080412 | | | | | 12.7 | | 4.76 | | |
| | | | | | | | | 7 | | |
|  LOGU0303... | LOGU0303... | | | | | 11.9 | 6.2 | 3.96 |  | |
|  ENMU0603... | ENMU0603... | | | | | 10 | 6 | 4.2 |  | |
|  SDMT0903... | SDMT0903... | | | | | 9 | | 3.18 |  | |
| | SDMT1004... | | | | | 10 | | 4.76 | | |
|  TPMT1103... | TPMT1103... | | | | | 11 | | 3.18 |  | |
|  SOMT1004... | SOMT1004... | | | | | 10.4 | | 4.76 |  | |

- 安定切削
- 一般切削
- ⊕ 不安定切削

- 安定切削
- 一般切削
- ⊕ 不安定切削

MTSR銑牙刀

Mill Thread Toolholders(MTSR)

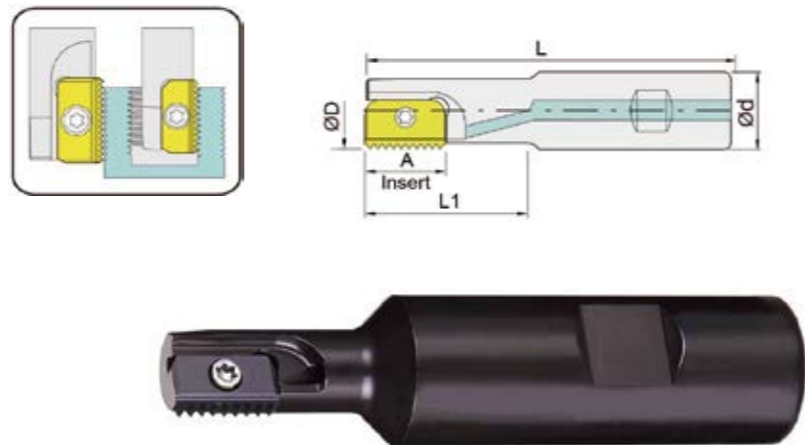

MTSR銑牙刀片

Insert Of Mill Thread Toolholders(MTSR)

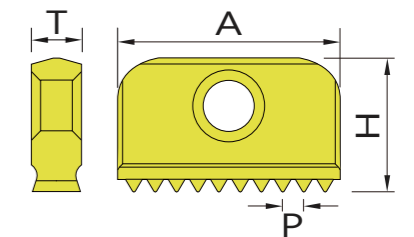

| | | | | |
|----|---|----|----|-----|
| 16 | E | 12 | UN | MT7 |
| 1 | 2 | 3 | 4 | 5 |

- 1 刀片邊長 Edge Length(mm)**
A=12, 14, 21, 30
- 2 刀片類型 Type of insert**
E 外螺紋, I 內螺紋, -- 外+內螺紋
- 3 牙距 Pitch**
- 4 螺紋規範 Thread Standard**
ISO 公制, ISO Metric; UN 美規, American UN; ACME 英制梯形螺紋 ACME; W 英制惠氏螺紋 Whitworth(BSW,BSF,BSP(G)); BSPT 英制錐管螺紋 British Standard Pipe Thread; NPT 美規錐管螺紋 NPT
- 5 刀片材質 Carbide Grade**
MT7 硬質合金

| 編碼 Item Code | | 尺寸 Dimensions (mm) | | | | | | 刀數 Teeth | 零件 Spare parts | 重量 (kg) |
|--------------------|--------------------|--------------------|------|----|------|-----|----|----------|----------------|---------|
| 無水孔 Non-coolant | 水孔 Coolant | A | D | d | d1 | L | L1 | | | |
| MTSR12-101-U20-085 | MTSR12-101-W20-085 | 12 | 9.9 | 20 | 7.5 | 85 | 16 | 1 | ① | 0.19 |
| MTSR14-141-U20-085 | MTSR14-141-W20-085 | 4 | 14.5 | 20 | 11 | 85 | 25 | 1 | ② | 0.17 |
| MTSR21-211-U20-094 | MTSR21-211-W20-094 | 21 | 21 | 20 | 16.5 | 94 | 40 | 1 | ③ | 0.23 |
| MTSR40-481-U40-153 | MTSR40-481-W40-153 | 40 | 48 | 40 | 35 | 153 | 78 | 1 | ⑤ | 1.29 |
| MTSR21-251-U20-125 | MTSR21-251-W20-125 | 21 | 25 | 20 | | 125 | 28 | 1 | ③ | 0.31 |
| MTSR30-311-U25-150 | MTSR30-311-W25-150 | 30 | 31 | 25 | | 150 | 42 | 1 | ④ | 0.58 |
| MTSR30-381-U32-150 | MTSR30-381-W32-150 | 30 | 38 | 32 | | 150 | 43 | 1 | ④ | 0.94 |
| MTSR14-202-U20-093 | MTSR14-202-W20-093 | 14 | 20 | 20 | 16 | 93 | 41 | 2 | ② | 0.22 |
| MTSR21-302-U25-108 | MTSR21-302-W25-108 | 21 | 30 | 25 | 24 | 108 | 52 | 2 | ③ | 0.42 |
| MTSR30-402-U32-130 | MTSR30-402-W32-130 | 30 | 40 | 32 | 30 | 130 | 70 | 2 | ④ | 0.72 |
| MTSR40-502-U40-153 | MTSR40-502-W40-153 | 40 | 50 | 40 | 38 | 153 | 78 | 2 | ⑤ | 1.29 |

| 零件 Spare parts | 刀片型號 Insert | Screw | Wrench |
|----------------|-------------|---------|--------|
| ① | 12I | MS2506J | ETF08 |
| ② | 14I/E | MS3008A | ETF09 |
| ③ | 21I/E | MS4011D | ETF15 |
| ④ | 30I/E | MS5015H | ETL25 |
| ⑤ | 40I/E | MS5022H | ETL25 |

| Description | 公制規格 Metric | Pitch (mm) | 英制規格 Inch | Pitch (TPI) | T | H | GRADE 材質 |
|-------------|-------------|------------|-----------|-------------|-----|-----|-----------|
| | | | | | | | Coated 塗層 |
| | | | | | | | MT7 |
| 12I | 0.5 ISO | 0.5 | 32 UN | 32 | 2.9 | 6.3 | |
| | 0.75 ISO | 0.75 | 28 UN | 28 | | | |
| | 1.0 ISO | 1.0 | 24 UN | 24 | | | |
| | 1.25 ISO | 1.25 | 20 UN | 20 | | | |
| | 1.5 ISO | 1.5 | 18 UN | 18 | | | |
| 14I/E | 0.5 ISO | 0.5 | 32 UN | 32 | 3.1 | 7.5 | |
| | 0.75 ISO | 0.75 | 28 UN | 28 | | | |
| | 1.0 ISO | 1.0 | 27 UN | 27 | | | |
| | 1.25 ISO | 1.25 | 24 UN | 24 | | | |
| | 1.5 ISO | 1.5 | 20 UN | 20 | | | |
| | 1.75 ISO | 1.75 | 18 UN | 18 | | | |
| | 2.0 ISO | 2.0 | 16 UN | 16 | | | |
| | 2.5 ISO | 2.5 | 14 UN | 14 | | | |
| | | | 12 UN | 12 | | | |
| | | | 11 UN | 11 | | | |
| 21I/E | 1.0 ISO | 1.0 | 24 UN | 24 | 4.7 | 12 | |
| | 1.5 ISO | 1.5 | 20 UN | 20 | | | |
| | 1.75 ISO | 1.75 | 18 UN | 18 | | | |
| | 2.0 ISO | 2.0 | 16 UN | 16 | | | |
| | 2.5 ISO | 2.5 | 14 UN | 14 | | | |
| | 3.0 ISO | 3.0 | 12 UN | 12 | | | |
| | 3.5 ISO | 3.5 | 11 UN | 11 | | | |
| | | | 10 UN | 10 | | | |
| | | | 8 UN | 8 | | | |
| | | | 7 UN | 7 | | | |
| 30I/E | 1.5 ISO | 1.5 | 20 UN | 20 | 5.5 | 16 | |
| | 2.0 ISO | 2.0 | 18 UN | 18 | | | |
| | 3.0 ISO | 3.0 | 16 UN | 16 | | | |
| | 3.5 ISO | 3.5 | 14 UN | 14 | | | |
| | 4.0 ISO | 4.0 | 12 UN | 12 | | | |
| | 4.5 ISO | 4.5 | 10 UN | 10 | | | |
| | 5.0 ISO | 5.0 | 8 UN | 8 | | | |
| | 5.5 ISO | 5.5 | 6 UN | 6 | | | |
| 40I/E | 1.5 ISO | 1.5 | 16 UN | 16 | 6.3 | 20 | |
| | 2.0 ISO | 2.0 | 14 UN | 14 | | | |
| | 3.0 ISO | 3.0 | 12 UN | 12 | | | |
| | 3.5 ISO | 3.5 | 8 UN | 8 | | | |
| | 4.0 ISO | 4.0 | 6 UN | 6 | | | |
| | 4.5 ISO | 4.5 | 4.5 UN | 4.5 | | | |
| | 5.0 ISO | 5.0 | 4 UN | 4 | | | |
| | 5.5 ISO | 5.5 | | | | | |
| | 6.0 ISO | 6.0 | | | | | |

(A) 銑刀
ENDMILLS
(B) 鑽頭
DRILLS
(C) 絞刀
REAMERS
(D) 絲攻
TAPS
(E) 刀桿/刀盤
MILLING CUTTERS
(F) 刀片
INSERTS

(A) 銑刀
ENDMILLS
(B) 鑽頭
DRILLS
(C) 絞刀
REAMERS
(D) 絲攻
TAPS
(E) 刀桿/刀盤
MILLING CUTTERS
(F) 刀片
INSERTS

45°面銑刀

45° FACE MILLING CUTTERS

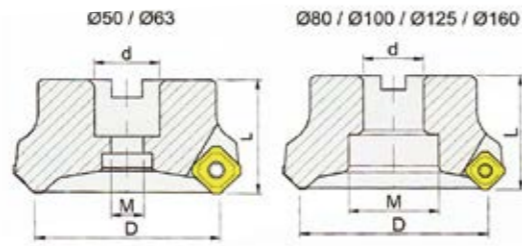

1. 加工鋼件Vc:350M/min
Steel process Vc:350M/min
2. 加工不銹鋼Vc:200M/min
Stainless steel process Vc:200M/min



| 產品編號 Item Code | 尺寸 Dimensions (mm) | | | | 刃數 Teeth | 刀片型號 Insert | 牌價 Price |
|--------------------------|--------------------|-------|----|----|-------------|--------------------------|-------------|
| | D | d | L | M | | | |
| Right hand | | | | | | | |
| OFV-SE13*050-220 | 50 | 22.0 | 40 | 11 | 4 | SE..13T3.. WE..13T3.. | |
| OFV-SE13*063-254 | 63 | 25.4 | 40 | 11 | 5 | | |
| OFV-SE13*080-254 | 80 | 25.4 | 50 | 38 | 6 | | |
| OFV-SE13*100-3175 | 100 | 31.75 | 50 | 45 | 7 | | |
| OFV-SE13*125*381 | 125 | 38.1 | 63 | 60 | 8 | | |
| OFV-SE13*160*508 | 160 | 50.8 | 63 | 80 | 10 | | |

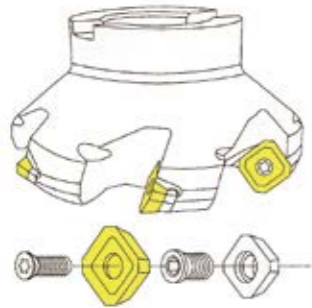

| 刀片型號 Description | M.C.T 磁浮刀片 M.C.T Insert Coated | |
|---------------------|-----------------------------------|---------|
| | WMG4130 | VMG4130 |
| | | |
| | | |
| | | |

| Shim | Screw | Wrench |
|---------|-----------|--------|
| | | |
| SSS445N | MDS05035S | PL35 |
| Screw | Wrench | |
| | | |
| MS3512B | T15 | |

| 刀片型號 Description | 刀片形狀 Insert Shape | 尺寸 Dimensions (mm) | | | |
|--------------------------------------|----------------------|--------------------|------|------------|-----|
| | | D | S | F | Re |
| SEMT13T3AGSN | | 13.4 | 3.97 | 1.9 | 1.5 |
| SEGT13T3AGFN | | 13.4 | 3.97 | 2.2 | --- |
| WEEW13T3AGER WEEW13T3AGTR | | 16.6 | 3.97 | 8.2 8.1 | 1.5 |

直角端銑刀

HOLDER/CUTTING END MILLS

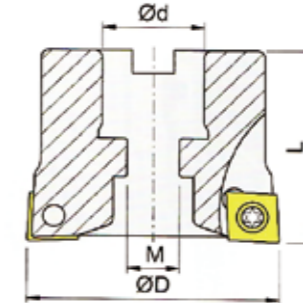

切削實例



| 產品編號 Item Code | 尺寸 Dimensions (mm) | | | | 刃數 Teeth | 刀片型號 Insert | Screw | Wrench | 牌價 Price |
|---------------------------|--------------------|-------|----|----|-------------|----------------|-------------|--------|-------------|
| | D | d | L | M | | | | | |
| OFV-ASV4050*220 | 50 | 22.0 | 50 | 11 | 3 | MPHW 120516 | MS 5011A | T20 | |
| OFV-ASV4063*254-4 | 63 | 25.4 | 50 | 13 | 4 | | | | |
| OFV-ASV6080*3175-5 | 80 | 31.75 | 50 | 13 | 5 | | | | |

| 刀片型號 Description | M.C.T 磁浮刀片 M.C.T Insert Coated | | |
|---------------------|-----------------------------------|---------|------------|
| | WMH9250 | VMH9250 | MPHW120516 |
| MPHW120516 | | | |
| MPMT120508 | | | |
| MPMT120516 | | | |

| 刀片型號 Description | 刀片形狀 Insert Shape | 尺寸 Dimensions (mm) | | |
|---------------------|----------------------|--------------------|------|-----|
| | | A | S | Re |
| MPHW120516 | | 12.7 | 5.56 | 1.6 |
| MPMT120508 | | 12.7 | 5.56 | 0.8 |
| MPMT120516 | | 12.7 | 5.56 | 1.6 |

(A) 銑刀
ENDMILLS
(B) 鑽頭
DRILLS
(C) 絞刀
REAMERS
(D) 絲攻
TAPS
(E) 刀桿/刀盤
MILLING CUTTERS
(F) 刀片
INSERTS

(A) 銑刀
ENDMILLS
(B) 鑽頭
DRILLS
(C) 絞刀
REAMERS
(D) 絲攻
TAPS
(E) 刀桿/刀盤
MILLING CUTTERS
(F) 刀片
INSERTS

直角端銑刀

HOLDER/CUTTING END MILLS

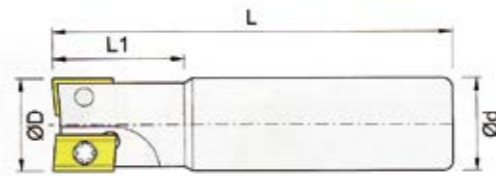

- 1. 高速精密加工專用。
Using in high speed and precise process.
- 2. 規格齊全。
Complete specifications.

3. 加工鋼件Vc:300M/min
Steel process Vc:300Mmin



| 產品編號 Item Code | 尺寸 Dimensions (mm) | | | | 刃數 Teeth | 刀片型號 Insert | Screw | Wrench | 牌價 Price |
|-------------------|--------------------|----|-----|----|-------------|----------------|-------------|--------|-------------|
| | D | d | L | L1 | | | | | |
| OMV-UEX1212-1500 | 12 | 12 | 150 | 25 | 1 | APET 120204 | MS 3506A | T15 | |
| OMV-UEX1213-150 | 13 | 12 | 150 | 20 | 1 | | | | |
| OMV-UEX1616-150 | 16 | 16 | 150 | 30 | 1 | | | | |
| OMV-UEX1616-200 | 16 | 16 | 200 | 30 | 1 | | | | |
| OMV-UEX1617-150 | 17 | 16 | 150 | 30 | 1 | | | | |
| OMV-UEX1617-200 | 17 | 16 | 200 | 30 | 1 | | | | |
| OMV-UEX2020-150 | 20 | 20 | 150 | 30 | 2 | | | | |
| OMV-UEX2020-200 | 20 | 20 | 200 | 30 | 2 | | | | |
| OMV-UEX2020-250 | 20 | 20 | 250 | 30 | 2 | | | | |
| OMV-UEX2021-150 | 21 | 20 | 150 | 30 | 2 | | | | |
| OMV-UEX2021-200 | 21 | 20 | 200 | 30 | 2 | | | | |
| OMV-UEX2525-150 | 25 | 25 | 150 | 40 | 2 | ADET 160308 | MS 3507A | T15 | |
| OMV-UEX2525-200 | 25 | 25 | 200 | 40 | 2 | | | | |
| OMV-UEX2525-250 | 25 | 25 | 250 | 40 | 2 | | | | |
| OMV-UEX2526-150 | 26 | 25 | 150 | 30 | 2 | | | | |
| OMV-UEX2526-200 | 26 | 25 | 200 | 30 | 2 | | | | |
| OMV-UEX2526-250 | 26 | 25 | 250 | 30 | 2 | | | | |
| OMV-UEX3232-150-3 | 32 | 32 | 150 | 45 | 3 | | | | |
| OMV-UEX3232-200-3 | 32 | 32 | 200 | 45 | 3 | | | | |
| OMV-UEX3232-250-3 | 32 | 32 | 250 | 45 | 3 | | | | |
| OMV-UEX3232-300-3 | 32 | 32 | 300 | 45 | 3 | | | | |
| OMV-UEX3233-150-3 | 33 | 32 | 150 | 35 | 3 | | | | |
| OMV-UEX3233-200-3 | 33 | 32 | 200 | 35 | 3 | | | | |
| OMV-UEX3233-250-3 | 33 | 32 | 250 | 35 | 3 | | | | |
| OMV-UEX3233-300-3 | 33 | 32 | 300 | 35 | 3 | | | | |

直角端銑刀

HOLDER/CUTTING END MILLS

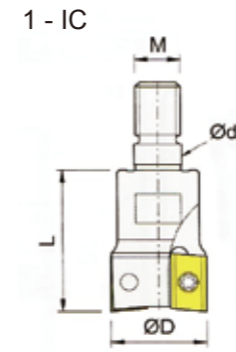

2 - IC

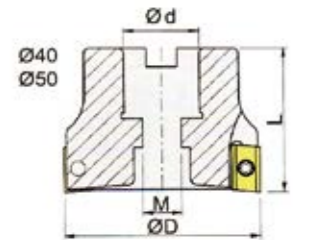

| 產品編號 1 - Item Code | 尺寸 Dimensions (mm) | | | | 刃數 Teeth | 刀片型號 Insert | Screw | Wrench | 牌價 Price |
|-----------------------|--------------------|------|----|-----|-------------|----------------|-------------|--------|-------------|
| | D | d | L | M | | | | | |
| OMVM-UEX161-08 | 16 | 8.5 | 28 | M8 | 1 | APET 120204 | MS 3507A | T15 | |
| OMVM-UEX171-08 | 17 | 8.5 | 28 | M8 | 1 | | | | |
| OMVM-UEX172-08 | 17 | 8.5 | 28 | M8 | 2 | | | | |
| OMVM-UEX182-08 | 18 | 8.5 | 28 | M8 | 2 | | | | |
| OMVM-UEX192-08 | 19 | 8.5 | 28 | M8 | 2 | | | | |
| OMVM-UEX202-10 | 20 | 10.5 | 30 | M10 | 2 | | | | |
| OMVM-UEX212-10 | 21 | 10.5 | 30 | M10 | 2 | | | | |
| OMVM-UEX222-10 | 22 | 10.5 | 30 | M10 | 2 | | | | |
| OMVM-UEX253-12 | 25 | 12.5 | 35 | M12 | 3 | | | | |
| OMVM-UEX263-12 | 26 | 12.5 | 35 | M12 | 3 | | | | |
| OMVM-UEX324-16 | 32 | 17 | 43 | M16 | 4 | ADET 160308 | MS 4009A | T15 | |
| OMVM-UEX334-16 | 33 | 17 | 43 | M16 | 4 | | | | |
| OMVM-UEX252-12 | 25 | 12.5 | 35 | M12 | 2 | | | | |
| OMVM-UEX262-12 | 26 | 12.5 | 35 | M12 | 2 | | | | |
| OMVM-UEX323-16 | 32 | 17 | 43 | M16 | 3 | | | | |
| OMVM-UEX333-16 | 33 | 17 | 43 | M16 | 3 | | | | |

| 產品編號 2 - Item Code | 尺寸 Dimensions (mm) | | | | 刃數 Teeth | 刀片型號 Insert | Screw | Wrench | 牌價 Price |
|-----------------------|--------------------|------|----|----|-------------|----------------|-------------|--------|-------------|
| | D | d | L | M | | | | | |
| OFV-UEX403*220 | 40 | 22.0 | 40 | 11 | 3 | ADET 160308 | MS 4011A | T15 | |
| OFV-UEX504*220 | 50 | 22.0 | 50 | 11 | 4 | | | | |

(A) 銑刀
ENDMILLS
(B) 鑽頭
DRILLS
(C) 絞刀
REAMERS
(D) 絲攻
TAPS
(E) 刀桿/刀盤
MILLING CUTTERS
(F) 刀片
INSERTS

(A) 銑刀
ENDMILLS
(B) 鑽頭
DRILLS
(C) 絞刀
REAMERS
(D) 絲攻
TAPS
(E) 刀桿/刀盤
MILLING CUTTERS
(F) 刀片
INSERTS

直角端銑刀

HOLDER/CUTTING END MILLS

| 刀片型號 Description | M.C.T 磁浮刀片 M.C.T Insert Coated | | |
|---------------------|--------------------------------|---------|---------|
| | WMH9250 | VMH9250 | WMH9550 |
| APNT120208 | | | |
| APET120204 | | | |
| ADNT160308 | | | |
| ADET160304 | | | |

| 刀片型號 Description | 刀片形狀 Insert Shape | 尺寸 Dimensions (mm) | | | | | |
|---------------------|----------------------|--------------------|-------|-----|-----|-----|----|
| | | A | B | S | r | d1 | θ° |
| APNT120208 | | 12.7 | 7.938 | 2.5 | 0.8 | 3.8 | 11 |
| APET120204 | | | | | 0.4 | | |
| ADNT160308 | | | | | 0.8 | | |
| ADET160304 | | | | | 0.4 | | |

| 被削材質 | 刀片材質 | 切削速度 (m/min) | 端銑刀刀徑 (mm) | | | | | | | | | | | | | | | |
|--------------------------|---------|--------------|------------|------------|---------|------------|---------|------------|---------|------------|---------|------------|---------|------------|---------|------------|--|--|
| | | | 16 | | 20 | | 25 | | 30 | | 35 | | 40 | | 50 | | | |
| | | | 回轉數 rpm | 進刀速度 mm/mm | 回轉數 rpm | 進刀速度 mm/mm | 回轉數 rpm | 進刀速度 mm/mm | 回轉數 rpm | 進刀速度 mm/mm | 回轉數 rpm | 進刀速度 mm/mm | 回轉數 rpm | 進刀速度 mm/mm | 回轉數 rpm | 進刀速度 mm/mm | | |
| 軟鋼 SS.SM (HB90~200) | CY250 | 150 | 2979 | 236 | 2389 | 386 | 1907 | 386 | 1596 | 386 | 1361 | 493 | 1189 | 493 | 954 | 536 | | |
| | CH550 | 180 | 3580 | 180 | 2860 | 290 | 2290 | 370 | 1910 | 370 | 1640 | 490 | 1430 | 490 | 1150 | 510 | | |
| 炭素鋼 合金鋼 SC.SCM (HRC30) | CY250 | 100 | 1990 | 160 | 1590 | 250 | 1270 | 250 | 1060 | 250 | 910 | 330 | 800 | 330 | 640 | 350 | | |
| | CH550 | 150 | 2980 | 150 | 2390 | 240 | 1910 | 310 | 1590 | 310 | 1360 | 410 | 1190 | 410 | 950 | 420 | | |
| 合金工具鋼 SKD.SKT (HRC30~40) | CY250 | 100 | 1988 | 163 | 1588 | 250 | 1275 | 250 | 1063 | 250 | 913 | 325 | 800 | 325 | 638 | 363 | | |
| | CH550 | 120 | 2376 | 192 | 1920 | 312 | 1536 | 312 | 1272 | 312 | 1080 | 384 | 960 | 384 | 768 | 408 | | |
| | WMH9250 | 300 | 5962 | 954 | 4770 | 572 | 1913 | 375 | 3180 | 508 | 1369 | 488 | 1200 | 488 | 1900 | 610 | | |
| 不銹鋼 SUS | CY250 | 125 | 2490 | 200 | 1990 | 320 | 1590 | 320 | 1330 | 320 | 1140 | 410 | 990 | 410 | 800 | 450 | | |
| | WMH9250 | 180 | 3586 | 288 | 2866 | 461 | 2290 | 461 | 1915 | 461 | 1642 | 590 | 1426 | 590 | 1152 | 648 | | |
| | VMH9250 | 220 | 4382 | 352 | 3502 | 563 | 2798 | 563 | 2341 | 563 | 2006 | 722 | 1742 | 722 | 1408 | 792 | | |
| 鑄鐵 FC.FCD (HB220 以下) | CY100H | 100 | 1988 | 238 | 1588 | 375 | 1275 | 375 | 1063 | 375 | 913 | 488 | 800 | 488 | 638 | 500 | | |
| | WMH9250 | 150 | 2981 | 300 | 2381 | 469 | 1913 | 469 | 1594 | 469 | 1369 | 619 | 1200 | 619 | 956 | 656 | | |
| 鋁合金 A133 | VMH9250 | 1000 | 19886 | 2971 | 15914 | 4771 | 12743 | 3829 | 10600 | 3171 | 9086 | 4086 | 7971 | 3600 | 6371 | 3829 | | |

高進給銑刀

HIGH FEED MILLING



| 產品編號 1 - Item Code | 尺寸 Dimensions (mm) | | | | 刀數 Teeth | 刀片型號 Insert | Screw | Wrench | 牌價 Price |
|-----------------------|--------------------|----|----|-----|-------------|----------------|----------|--------|-------------|
| | D | d | L | M | | | | | |
| OMVM-ASRF32-M16 | 32 | 17 | 43 | M16 | 2 | SD.. 1205 | MS 4011G | T15 | |
| OMVM-ASRF35-M16 | 35 | 17 | 43 | M16 | 3 | | | | |
| OMVM-ASRF40-M16 | 40 | 17 | 43 | M16 | 4 | | | | |
| OMVM-ASRF42-M16 | 42 | 17 | 43 | M16 | 4 | | | | |

| 產品編號 2 - Item Code | 尺寸 Dimensions (mm) | | | | 刀數 Teeth | 刀片型號 Insert | Screw | Wrench | 牌價 Price |
|-----------------------|--------------------|------|----|----|-------------|----------------|----------|--------|-------------|
| | D | d | L | M | | | | | |
| OFV-ASRF042*160-4 | 42 | 16.0 | 40 | 9 | 4 | SD.. 1205 | MS 4011G | T15 | |
| OFV-ASRF050*220-4 | 50 | 22.0 | 50 | 11 | 4 | | | | |
| OFV-ASRF050*254-5 | 50 | 25.4 | 50 | 11 | 5 | | | | |
| OFV-ASRF063*220-4 | 63 | 22.0 | 50 | 11 | 4 | | | | |
| OFV-ASRF063*254-5 | 63 | 25.4 | 50 | 11 | 5 | | | | |
| OFV-ASRF063*270-4 | 63 | 27.0 | 50 | 13 | 4 | | | | |
| OFV-ASRF063*254-5 | 63 | 25.4 | 50 | 13 | 5 | | | | |
| OFV-ASRF066*270-6 | 66 | 27.0 | 50 | 13 | 6 | | | | |
| OFV-ASRF080*254-6 | 80 | 25.4 | 50 | 13 | 6 | | | | |
| OFV-ASRF080*270-7 | 80 | 27.0 | 50 | 13 | 7 | | | | |

| 刀片型號 Description | M.C.T 磁浮刀片 M.C.T Insert Coated | | |
|---------------------|--------------------------------|---------|---------|
| | WMH9020 | VMH9020 | VMH9120 |
| SDNW1205 | | | |
| SDMT1205 | | | |

| 刀片型號 Description | 刀片形狀 Insert Shape | 尺寸 Dimensions (mm) | | | |
|---------------------|----------------------|--------------------|------|------|----|
| | | A | B | S | R |
| SDNW1205 | | 12.7 | 12.7 | 5.56 | 15 |
| SDMT1205 | | | | | |

(A) 銑刀
ENDMILLS
(B) 鑽頭
DRILLS
(C) 絞刀
REAMERS
(D) 絲攻
TAPS
(E) 刀桿/刀盤
MILLING CUTTERS
(F) 刀片
INSERTS

(A) 銑刀
ENDMILLS
(B) 鑽頭
DRILLS
(C) 絞刀
REAMERS
(D) 絲攻
TAPS
(E) 刀桿/刀盤
MILLING CUTTERS
(F) 刀片
INSERTS

直角端銑刀

HOLDER/CUTTING END MILLS

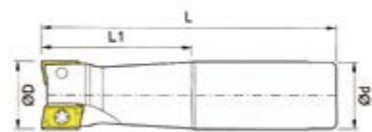

| 產品編號 Item Code | 尺寸 Dimensions (mm) | | | | 刃數 Teeth | 刀片型號 Insert | Screw | Wrench | 牌價 Price | | | |
|-------------------|--------------------|----|-----|----|-------------|----------------|-------------|--------|----------------|-------------|-----|--|
| | D | d | L | L1 | | | | | | | | |
| OMV-0602XO06-80 | 6 | 8 | 80 | 15 | 1 | XOMX 0602.. | MS 1804A | T06 | | | | |
| OMV-0602XO08-100 | 8 | 8 | 100 | 15 | 1 | | | | | | | |
| OMV-0602XO10-120 | 10 | 10 | 120 | 20 | 2 | | | | | | | |
| OMV-0602XO11-110 | 11 | 10 | 110 | 13 | 2 | | | | | | | |
| OMV-0602XO12-100 | 12 | 12 | 100 | 25 | 2 | | | | | | | |
| OMV-0602XO12-130 | 12 | 12 | 130 | 25 | 2 | | | | | | | |
| OMV-0602XO13-130 | 13 | 12 | 130 | 18 | 2 | | | | | | | |
| OMV-0602XO16-150 | 16 | 16 | 150 | 28 | 4 | | | | | | | |
| OMV-0602XO16-200 | 16 | 16 | 200 | 28 | 4 | | | | | | | |
| OMV-0602XO17-150 | 17 | 16 | 150 | 20 | 4 | | | | | | | |
| OMV-0903XO16-150 | 16 | 16 | 150 | 28 | 2 | | | | XOMX 0903.. | MS 2506E | T08 | |
| OMV-0903XO16-200 | 16 | 16 | 200 | 28 | 2 | | | | | | | |
| OMV-0903XO17-150 | 17 | 16 | 150 | 20 | 2 | | | | | | | |
| OMV-0903XO17-200 | 17 | 16 | 200 | 20 | 2 | | | | | | | |
| OMV-0903XO20-150 | 20 | 20 | 150 | 30 | 2 | | | | | | | |
| OMV-0903XO20-200 | 20 | 20 | 200 | 30 | 2 | | | | | | | |
| OMV-0903XO21-150 | 21 | 20 | 150 | 30 | 2 | | | | | | | |
| OMV-0903XO21-200 | 21 | 20 | 200 | 30 | 2 | | | | | | | |
| OMV-0903XO25-150 | 25 | 25 | 150 | 35 | 3 | | | | | | | |
| OMV-0903XO25-200 | 25 | 25 | 200 | 35 | 3 | | | | | | | |
| OMV-0903XO26-150 | 26 | 25 | 150 | 30 | 3 | | | | | | | |
| OMV-0903XO26-200 | 26 | 25 | 200 | 30 | 3 | | | | | | | |
| OMV-0903XO32-150 | 32 | 32 | 150 | 35 | 5 | | | | | | | |
| OMV-0903XO32-200 | 32 | 32 | 200 | 35 | 5 | | | | | | | |
| OMV-10T3XO16-150 | 16 | 16 | 150 | 22 | 2 | XOMT 10T3.. | MS 2506E | T08 | | | | |
| OMV-10T3XO20-150 | 20 | 20 | 150 | 28 | 2 | | | | | | | |
| OMV-1204XO25-150 | 25 | 20 | 150 | 30 | 2 | XOMT 1204.. | MS3507E | T10 | | | | |
| OMV-1204XO30-150 | 30 | 25 | 150 | 35 | 4 | | | | | | | |
| OMV-1204XO35-150 | 35 | 32 | 150 | 35 | 4 | | | | | | | |
| OMV-1204XO40-150 | 40 | 32 | 150 | 35 | 4 | | | | | | | |

直角端銑刀

HOLDER/CUTTING END MILLS

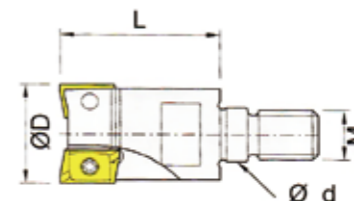

| 產品編號 Item Code | 尺寸 Dimensions (mm) | | | | 刃數 Teeth | 刀片型號 Insert | Screw | Wrench | 牌價 Price |
|-------------------|--------------------|------|----|-----|-------------|----------------|-------------|--------|-------------|
| | D | d | L | M | | | | | |
| OMVM-0602XO102-05 | 10 | 5.5 | 16 | M5 | 2 | XOMX 0602.. | MS 1804A | T06 | |
| OMVM-0602XO112-05 | 11 | 5.5 | 16 | M5 | 2 | | | | |
| OMVM-0602XO122-06 | 12 | 6.5 | 18 | M6 | 2 | | | | |
| OMVM-0602XO132-06 | 13 | 6.5 | 18 | M6 | 2 | | | | |
| OMVM-0602XO164-08 | 16 | 8.5 | 20 | M8 | 4 | | | | |
| OMVM-0602XO184-08 | 18 | 8.5 | 20 | M8 | 4 | | | | |
| OMVM-0602XO205-10 | 20 | 10.5 | 24 | M10 | 5 | | | | |
| OMVM-0602XO255-12 | 25 | 12.5 | 28 | M12 | 5 | | | | |
| OMVM-0903XO162-08 | 16 | 8.5 | 25 | M8 | 2 | XOMX 0903.. | MS 2506E | T08 | |
| OMVM-0903XO172-08 | 17 | 8.5 | 25 | M8 | 2 | | | | |
| OMVM-0903XO202-10 | 20 | 10.5 | 30 | M10 | 2 | | | | |
| OMVM-0903XO212-10 | 21 | 10.5 | 30 | M10 | 2 | | | | |
| OMVM-0903XO253-12 | 25 | 12.5 | 35 | M12 | 3 | | | | |
| OMVM-0903XO264-12 | 26 | 12.5 | 35 | M12 | 4 | | | | |
| OMVM-0903XO325-16 | 32 | 17 | 43 | M16 | 5 | | | | |
| OMVM-0903XO335-16 | 33 | 17 | 43 | M16 | 5 | | | | |

| 刀片型號 Description | M.C.T 磁浮刀片 M.C.T Insert Coated | | | |
|---------------------|--------------------------------|--------|--------|--------|
| | WMO840 | VMO840 | WMX120 | VMX120 |
| XOET060204.. | | | | |
| XOMT060204.. | | | | |
| XOMT090304.. | | | | |
| XOMT10T304.. | | | | |
| XOMT120408.. | | | | |

| 刀片型號 Description | 刀片形狀 Insert Shape | 尺寸 Dimensions (mm) | | | |
|---------------------|----------------------|--------------------|------|------|-----|
| | | A | B | S | Re |
| XOET060204.. | | 6.94 | 4.09 | 2.45 | 0.4 |
| XOMT060204.. | | 6.91~6.94 | 4.09 | 2.45 | 0.4 |
| XOMT090304.. | | 9 | 6.4 | 3.65 | 0.4 |
| XOMT10T304.. | | 9.3 | 6.9 | 3.83 | 0.4 |
| XOMT120408.. | | 11.6 | 8.2 | 5.07 | 0.8 |

(A) 銑刀
ENDMILLS
(B) 鑽頭
DRILLS
(C) 絞刀
REAMERS
(D) 絲攻
TAPS
(E) 刀桿/刀盤
MILLING CUTTERS
(F) 刀片
INSERTS

(A) 銑刀
ENDMILLS
(B) 鑽頭
DRILLS
(C) 絞刀
REAMERS
(D) 絲攻
TAPS
(E) 刀桿/刀盤
MILLING CUTTERS
(F) 刀片
INSERTS

直角端銑刀

HOLDER/CUTTING END MILLS

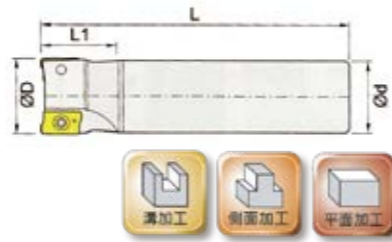

(A) 銑刀
ENDMILLS
(B) 鑽頭
DRILLS
(C) 絞刀
REAMERS
(D) 絲攻
TAPS
(E) 刀桿/刀盤
MILLING CUTTERS
(F) 刀片
INSERTS

| 產品編號 Item Code | 尺寸 Dimensions (mm) | | | | 刃數 Teeth | 刀片型號 Insert | Screw | Wrench | 牌價 Price |
|--------------------|--------------------|----|-----|----|-------------|-----------------|-------------|--------|-------------|
| | D | d | L | L1 | | | | | |
| OMV-11AD1616-150 | 16 | 16 | 150 | 28 | 2 | ADMT -11T3.. | MS 2506B | T09 | |
| OMV-11AD1616-200 | 16 | 16 | 200 | 28 | 2 | | | | |
| OMV-11AD1716-150 | 17 | 16 | 150 | 20 | 2 | | | | |
| OMV-11AD1716-200 | 17 | 16 | 200 | 20 | 2 | | | | |
| OMV-11AD1816-150 | 18 | 16 | 150 | 20 | 2 | | | | |
| OMV-11AD1816-200 | 18 | 16 | 200 | 20 | 2 | | | | |
| OMV-11AD2020-150 | 20 | 20 | 150 | 30 | 2 | | | | |
| OMV-11AD2020-200 | 20 | 20 | 200 | 30 | 2 | | | | |
| OMV-11AD2120-150 | 21 | 20 | 150 | 20 | 2 | | | | |
| OMV-11AD2120-200 | 21 | 20 | 200 | 20 | 2 | | | | |
| OMV-11AD2220-150 | 22 | 20 | 150 | 30 | 2 | | | | |
| OMV-11AD2220-200 | 22 | 20 | 200 | 30 | 2 | | | | |
| OMV-11AD2525*150-4 | 25 | 25 | 150 | 35 | 4 | | | | |
| OMV-11AD2525*200-4 | 25 | 25 | 200 | 35 | 4 | | | | |
| OMV-11AD2625*150-4 | 26 | 25 | 150 | 25 | 4 | | | | |
| OMV-11AD2625*200-4 | 26 | 25 | 200 | 25 | 4 | | | | |
| OMV-11AD3032-150 | 30 | 32 | 150 | 40 | 4 | MS 2506B | T09 | | |
| OMV-11AD3032-200 | 30 | 32 | 200 | 40 | 4 | | | | |
| OMV-11AD3032-250 | 30 | 32 | 250 | 40 | 4 | | | | |
| OMV-11AD3232-150 | 32 | 32 | 150 | 40 | 4 | | | | |
| OMV-11AD3232-200 | 32 | 32 | 200 | 40 | 4 | | | | |
| OMV-11AD3232-250 | 32 | 32 | 250 | 40 | 4 | | | | |
| OMV-11AD3332-150 | 33 | 32 | 150 | 32 | 4 | | | | |
| OMV-11AD3332-200 | 33 | 32 | 200 | 32 | 4 | | | | |
| OMV-11AD3332-250 | 33 | 32 | 250 | 32 | 4 | | | | |
| OMV-17AD2525-150 | 25 | 25 | 150 | 32 | 2 | ADMT -1704.. | MS 3509A | T15 | |
| OMV-17AD2525-200 | 25 | 25 | 200 | 32 | 2 | | | | |
| OMV-17AD2625-150 | 26 | 25 | 150 | 32 | 2 | | | | |
| OMV-17AD2625-200 | 26 | 25 | 200 | 32 | 2 | | | | |
| OMV-17AD2625-250 | 26 | 25 | 250 | 32 | 2 | | | | |
| OMV-17AD3232-150 | 32 | 32 | 150 | 35 | 3 | | | | |
| OMV-17AD3232-200 | 32 | 32 | 200 | 35 | 3 | | | | |
| OMV-17AD3332-150 | 33 | 32 | 150 | 35 | 3 | | | | |
| OMV-17AD3332-200 | 33 | 32 | 200 | 35 | 3 | | | | |
| OMV-17AD3332-250 | 33 | 32 | 250 | 35 | 3 | | | | |

直角端銑刀

HOLDER/CUTTING END MILLS

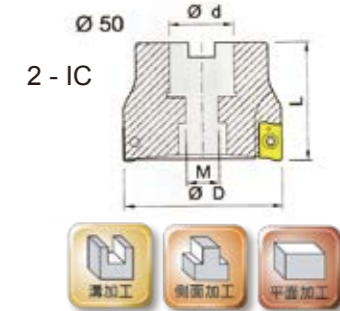
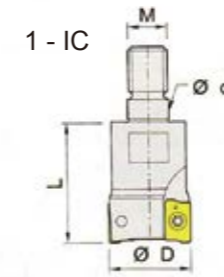

(A) 銑刀
ENDMILLS
(B) 鑽頭
DRILLS
(C) 絞刀
REAMERS
(D) 絲攻
TAPS
(E) 刀桿/刀盤
MILLING CUTTERS
(F) 刀片
INSERTS

| 產品編號 1 - Item Code | 尺寸 Dimensions (mm) | | | | 刃數 Teeth | 刀片型號 Insert | Screw | Wrench | 牌價 Price |
|-----------------------|--------------------|------|----|-----|-------------|-----------------|-------------|--------|-------------|
| | D | d | L | M | | | | | |
| OMVM-11AD162-M08 | 16 | 8.5 | 26 | M8 | 2 | ADMT -11T3.. | MS 2506B | T09 | |
| OMVM-11AD172-M08 | 17 | 8.5 | 26 | M8 | 2 | | | | |
| OMVM-11AD202-M10 | 20 | 10.5 | 30 | M10 | 2 | | | | |
| OMVM-11AD203-M10 | 20 | 10.5 | 30 | M10 | 3 | | | | |
| OMVM-11AD212-M10 | 21 | 10.5 | 30 | M10 | 2 | | | | |
| OMVM-11AD213-M10 | 21 | 10.5 | 30 | M10 | 3 | | | | |
| OMVM-11AD253-M12 | 25 | 12.5 | 35 | M12 | 3 | | | | |
| OMVM-11AD254-M12 | 25 | 12.5 | 35 | M12 | 4 | | | | |
| OMVM-11AD263-M12 | 26 | 12.5 | 35 | M12 | 3 | | | | |
| OMVM-11AD264-M12 | 26 | 12.5 | 35 | M12 | 4 | | | | |
| OMVM-11AD324-M16 | 32 | 17 | 43 | M16 | 4 | | | | |
| OMVM-11AD325-M16 | 32 | 17 | 43 | M16 | 5 | | | | |
| OMVM-11AD334-M16 | 33 | 17 | 43 | M16 | 4 | | | | |
| OMVM-11AD335-M16 | 33 | 17 | 43 | M16 | 5 | | | | |
| OMVM-11AD354-M16 | 35 | 17 | 43 | M16 | 4 | | | | |
| OMVM-11AD355-M16 | 35 | 17 | 43 | M16 | 5 | | | | |
| OMVM-17AD252-M12 | 25 | 12.5 | 35 | M12 | 2 | R390 -1704.. | MS 3509A | T15 | |
| OMVM-17AD262-M12 | 26 | 12.5 | 35 | M12 | 2 | | | | |
| OMVM-17AD323-M16 | 32 | 17 | 43 | M16 | 3 | | | | |
| OMVM-17AD333-M16 | 33 | 17 | 43 | M16 | 3 | | | | |

| 產品編號 2 - Item Code | 尺寸 Dimensions (mm) | | | | 刃數 Teeth | 刀片型號 Insert | Screw | Wrench | 牌價 Price |
|-----------------------|--------------------|------|----|----|-------------|-----------------|-------------|--------|-------------|
| | D | d | L | M | | | | | |
| OFV-11AD05005*220 | 50 | 22.0 | 40 | 11 | 5 | ADMT -11T3.. | MS 2506B | T09 | |
| OFV-11AD05007*220 | 50 | 22.0 | 40 | 11 | 7 | | | | |
| OFV-17AD05004*220 | 50 | 22.0 | 50 | 11 | 4 | R390-1704.. | MS3509A | T15 | |

| 刀片型號 Description | 刀片形狀 Insert Shape | 尺寸 Dimensions (mm) | | | |
|---------------------|----------------------|--------------------|-----|------|-----|
| | | A | B | S | Re |
| R390-11T308 | | 11 | 6.8 | 3.59 | 0.8 |
| R390-170408 | | 17 | 9.6 | 4.76 | 0.8 |

高進給銑刀

HIGH FEED MILLING



可高速切削
SKD61 Vc:350m/min(300-400n/min)
SUS Vc:200m/min(150-250m/min)
06AJX20x150-3

| 產品編號 Item Code | 尺寸 Dimensions (mm) | | | | 刃數 Teeth | 刀片型號 Insert | Screw | Wrench | Screw | Clamp | Wrench | 牌價 Price | | | | | | |
|--------------------|--------------------|----|-----|----|-------------|----------------|----------|--------|-------|-------|--------|-------------|----------|--------|----------|----------|--------|--|
| | D | d | L | L1 | | | | | | | | | | | | | | |
| OMV-AJX06R20-150 | 20 | 20 | 150 | 25 | 3 | WD..06T2... | MS 2506B | ETF 09 | --- | --- | --- | | | | | | | |
| OMV-AJX06R22-150 | 22 | 20 | 150 | 25 | 3 | WD..0803... | MS 3008A | ETF 09 | --- | --- | --- | | | | | | | |
| OMV-AJX08R20-150 | 20 | 20 | 150 | 30 | 2 | | | | | | | | | | | | | |
| OMV-AJX08R20-200 | 20 | 20 | 200 | 30 | 2 | | | | | | | | | | | | | |
| OMV-AJX08R21-150 | 21 | 20 | 150 | 20 | 2 | | | | | | | | | | | | | |
| OMV-AJX08R21-200 | 21 | 20 | 200 | 20 | 2 | | | | | | | | | | | | | |
| OMV-AJX08R22-150 | 22 | 20 | 150 | 25 | 2 | | | | | | | | | | | | | |
| OMV-AJX08R22-200 | 22 | 20 | 200 | 25 | 2 | | | | | | | | | | | | | |
| OMV-AJX08R25-150 | 25 | 25 | 150 | 35 | 3 | | | | | | | | | | | | | |
| OMV-AJX08R25-200 | 25 | 25 | 200 | 35 | 3 | | | | | | | | | | | | | |
| OMV-AJX08R26-150 | 26 | 25 | 150 | 30 | 3 | | | | | | | | | | | | | |
| OMV-AJX08R26-200 | 26 | 25 | 200 | 30 | 3 | | | | | | | | | | | | | |
| OMV-AJX08R35-150 | 35 | 32 | 150 | 30 | 3 | | | | | | | | | | | | | |
| OMV-AJX08R35-200 | 35 | 32 | 200 | 30 | 3 | | | | | | | | | | | | | |
| OMV-AJX12R32-150 | 32 | 32 | 150 | 45 | 2 | | | | | | | WD..1204... | MS 4011G | ETF 15 | MS 3509A | MC35-143 | ETF 15 | |
| OMV-AJX12R32-200 | 32 | 32 | 200 | 45 | 2 | | | | | | | | | | | | | |
| OMV-AJX12R32-250 | 32 | 32 | 250 | 45 | 2 | | | | | | | | | | | | | |
| OMV-AJX12R40-150 | 40 | 32 | 150 | 35 | 3 | | | | | | | | | | | | | |
| OMV-AJX12R40-200 | 40 | 32 | 200 | 35 | 3 | | | | | | | | | | | | | |
| OMV-AJX12R40-250 | 40 | 32 | 250 | 35 | 3 | | | | | | | | | | | | | |
| OMV-AJX12R40-300 | 40 | 32 | 300 | 35 | 3 | | | | | | | | | | | | | |
| OMV-AJX12R40-150 | 40 | 42 | 150 | 70 | 3 | | | | | | | | | | | | | |
| OMV-AJX12R40-200 | 40 | 42 | 200 | 70 | 3 | | | | | | | | | | | | | |
| OMV-AJX12R40-200-3 | 40 | 42 | 200 | 70 | 3 | | | | | | | | | | | | | |

高進給銑刀

HIGH FEED MILLING

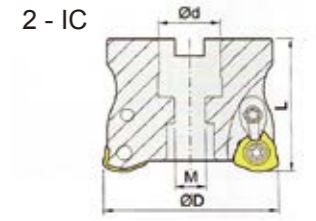
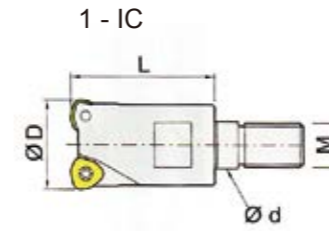

| 產品編號 1 - Item Code | 尺寸 Dimensions (mm) | | | | 刃數 Teeth | 刀片型號 Insert | Screw | Wrench | Screw | Clamp | Wrench | 牌價 Price |
|-----------------------|--------------------|------|----|-----|-------------|----------------|----------|--------|-------|-------|--------|-------------|
| | D | d | L | M | | | | | | | | |
| OMVM-AJX08R21-M10 | 21 | 10.5 | 30 | M10 | 2 | JO..0803 | MS 3008A | ETF 09 | --- | --- | --- | |
| OMVM-AJX08R25-M12 | 25 | 12.5 | 35 | M12 | 3 | | | | | | | |
| OMVM-AJX08R26-M12 | 26 | 12.5 | 35 | M12 | 3 | | | | | | | |
| OMVM-AJX08R28-M12 | 28 | 12.5 | 35 | M12 | 3 | | | | | | | |
| OMVM-AJX08R32-M16 | 32 | 17 | 43 | M16 | 3 | | | | | | | |
| OMVM-AJX08R35-M16 | 35 | 17 | 43 | M16 | 3 | | | | | | | |

| 產品編號 2 - Item Code | 尺寸 Dimensions (mm) | | | | 刃數 Teeth | 刀片型號 Insert | Screw | Wrench | Screw | Clamp | Wrench | 牌價 Price |
|-----------------------|--------------------|------|----|----|-------------|----------------|----------|--------|----------|----------|--------|-------------|
| | D | d | L | M | | | | | | | | |
| OFV-AJX12R50*22-3 | 50 | 22.0 | 50 | 11 | 3 | JD..1204 | MS 4011G | ETF 15 | MS 3509A | MC35-143 | ETF 15 | |
| OFV-AJX12R50*22-4 | 50 | 22.0 | 50 | 11 | 4 | | | | | | | |
| OFV-AJX12R63*22-4 | 63 | 22.0 | 50 | 11 | 4 | | | | | | | |
| OFV-AJX14R63*22-4 | 63 | 22.0 | 50 | 11 | 4 | | | | | | | JD..1405 |

| 刀片型號 Description | 刀片形狀 Insert Shape | 牌價 Price | | 尺寸 Dimensions (mm) | | | |
|---------------------|----------------------|----------|---------|--------------------|------|-----|----|
| | | VMH4020 | VMM4020 | B | S | Re | θ° |
| JO..06T2.. | | | | 6.35 | 2.78 | 1.5 | 13 |
| JO..0803.. | | | | 8.00 | 3.18 | 2.0 | 13 |
| JO..09T3.. | | | | 9.525 | 3.97 | 2.0 | 13 |
| JD..120420 | | | | 12.00 | 4.76 | 2.0 | 15 |
| JD..140520 | | | | 14.00 | 5.56 | 2.0 | 15 |

(A) 銑刀
ENDMILLS
(B) 鑽頭
DRILLS
(C) 絞刀
REAMERS
(D) 絲攻
TAPS
(E) 刀桿/刀盤
MILLING CUTTERS
(F) 刀片
INSERTS

(A) 銑刀
ENDMILLS
(B) 鑽頭
DRILLS
(C) 絞刀
REAMERS
(D) 絲攻
TAPS
(E) 刀桿/刀盤
MILLING CUTTERS
(F) 刀片
INSERTS

高進給銑刀
HIGH FEED MILLING

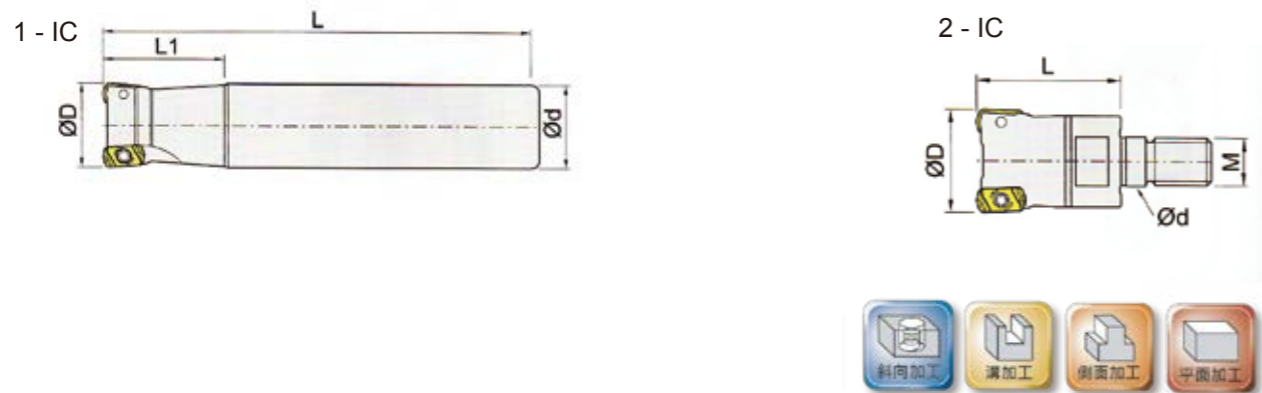

| 產品編號 1 - Item Code | 尺寸 Dimensions (mm) | | | | 刃數 Teeth | 刀片型號 Insert | Screw | Wrench | 牌價 Price |
|-----------------------|--------------------|----|-----|----|-------------|----------------|-------------|--------|-------------|
| | D | d | L | L1 | | | | | |
| OMV-EXN1616-150 | 16 | 16 | 150 | 30 | 2 | LUMN 0303 | MS 2506E | T08 | |
| OMV-EXN1716-150 | 17 | 16 | 150 | 25 | 2 | | | | |
| OMV-EXN2020-150 | 20 | 20 | 150 | 35 | 3 | | | | |
| OMV-EXN2120-150 | 21 | 20 | 150 | 30 | 3 | | | | |
| OMV-EXN2525-150 | 25 | 25 | 150 | 35 | 4 | | | | |
| OMV-EXN2625-150 | 26 | 25 | 150 | 35 | 4 | | | | |

| 產品編號 2 - Item Code | 尺寸 Dimensions (mm) | | | | 刃數 Teeth | 刀片型號 Insert | Screw | Wrench | 牌價 Price |
|-----------------------|--------------------|------|----|-----|-------------|----------------|-------------|--------|-------------|
| | D | d | L | M | | | | | |
| OMVM-EXN17-M8 | 17 | 8.5 | 25 | M8 | 2 | LUMN 0303 | MS 2506E | T08 | |
| OMVM-EXN21-M10 | 21 | 10.5 | 30 | M10 | 3 | | | | |

| 刀片型號 Description | 刀片形狀 Insert Shape | 尺寸 Dimensions (mm) | | | |
|---------------------|----------------------|--------------------|---|------|-----|
| | | A | B | S | Re |
| LUMN030310 | | 11.59 | 6 | 4.29 | 1.2 |

圓刃銑刀
CORNER ROUNDING END MILLS

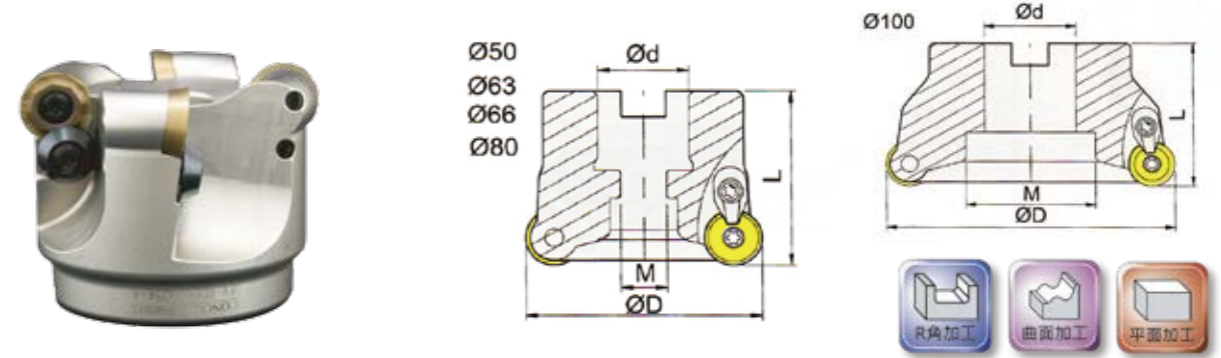

| 產品編號 Item Code | 尺寸 Dimensions (mm) | | | | 刃數 Teeth | 刀片型號 Insert | Screw | Wrench | Screw | Clamp | Wrench | 牌價 Price | | | | | | |
|-------------------|--------------------|-------|----|----|-------------|----------------|-------------|--------|-------------|--------------|--------|--------------|--------------|-----|---------------|-----------|-----|--|
| | D | d | L | M | | | | | | | | | | | | | | |
| OFV-RD5R40*160 | 40 | 16.0 | 40 | 9 | 5 | RD.. 10T3 | MS 4009B | T15 | MS 3509A | MC35 -143 | T15 | | | | | | | |
| OFV-RD5R50*220-4 | 50 | 22.0 | 50 | 11 | 4 | | | | | | | | | | | | | |
| OFV-RD5R50*220-5 | 50 | 22.0 | 40 | 11 | 5 | | | | | | | | | | | | | |
| OFV-RD5R52*220 | 52 | 22.0 | 50 | 11 | 5 | | | | | | | | | | | | | |
| OFV-RD6R50*220-4 | 50 | 22.0 | 50 | 11 | 4 | RD.. 1204 | MS 4011A | T15 | MS 3509A | MC35 -143 | T15 | | | | | | | |
| OFV-RD6R50*220-5 | 50 | 22.0 | 50 | 11 | 5 | | | | | | | | | | | | | |
| OFV-RD6R52*220 | 52 | 22.0 | 50 | 11 | 5 | RD.. 1204 | MS 4009A | T15 | MS 3509A | MC35 -143 | T15 | | | | | | | |
| OFV-RD6R63*220-5 | 63 | 22.0 | 50 | 11 | 5 | | | | | | | | | | | | | |
| OFV-RD6R63*220-6 | 63 | 22.0 | 50 | 11 | 6 | | | | | | | | | | | | | |
| OFV-RD6R66*220 | 66 | 22.0 | 50 | 11 | 6 | | | | | | | | | | | | | |
| OFV-RD6R63*270 | 63 | 27.0 | 50 | 13 | 5 | | | | | | | | | | | | | |
| OFV-RD6R80*270-5 | 80 | 27.0 | 50 | 13 | 5 | | | | | | | | | | | | | |
| OFV-RD6R80*270-6 | 80 | 27.0 | 50 | 13 | 6 | | | | | | | | | | | | | |
| OFV-RD6R80*270-7 | 80 | 27.0 | 50 | 13 | 7 | | | | | | | | | | | | | |
| OFV-RD8R50*220 | 50 | --- | 45 | 11 | 3 | | | | | | | RD.. 1604 | SCR- CRS5 | T20 | SCR- W1/4S | CL- 8P | T20 | |
| OFV-RD8R63*270 | 63 | 25.4 | 50 | 11 | 3/4 | | | | | | | | | | | | | |
| OFV-RD8R66*254 | 66 | 25.4 | 50 | 11 | 4 | | | | | | | | | | | | | |
| OFV-RD8R80*270 | 80 | 25.4 | 50 | 13 | 5 | | | | | | | | | | | | | |
| OFV-RD8R100*3175 | 100 | 31.75 | 55 | ?? | 5 | | | | | | | | | | | | | |
| OFV-RD8R116*3175 | 116 | 31.75 | 60 | ?? | 6 | | | | | | | | | | | | | |
| | | | | | | | | | | | | | | | | | | |

| 刀片型號 Description | 刀片形狀 Insert Shape | 尺寸 Dimensions (mm) | | |
|---------------------|----------------------|--------------------|------|-----|
| | | lc | S | d1 |
| RDMT10T3 | | 10 | 3.97 | 4.5 |
| RDMT1204 | | 12 | 4.76 | 4.5 |
| RDMT1604 | | 16 | 4.76 | 5.5 |

(A) 銑刀
ENDMILLS
(B) 鑽頭
DRILLS
(C) 絞刀
REAMERS
(D) 絲攻
TAPS
(E) 刀桿/刀盤
MILLING CUTTERS
(F) 刀片
INSERTS

(A) 銑刀
ENDMILLS
(B) 鑽頭
DRILLS
(C) 絞刀
REAMERS
(D) 絲攻
TAPS
(E) 刀桿/刀盤
MILLING CUTTERS
(F) 刀片
INSERTS

圓刃銑刀

CORNER ROUNDING END MILLS

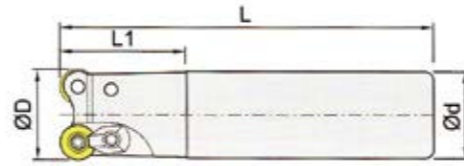

| 產品編號 Item Code | 尺寸 Dimensions (mm) | | | | 刃數 Teeth | 刀片型號 Insert | Screw | Wrench | Screw | Clamp | Wrench | 牌價 Price |
|------------------------|--------------------|----|-----|----|-------------|----------------|----------|--------|----------|----------|--------|-------------|
| | D | d | L | L1 | | | | | | | | |
| OMV-RBM3R2020-150 | 20 | 20 | 150 | 35 | 2 | RP..0602 | MS 2506A | T09 | MS 3509A | MC35-143 | T15 | |
| OMV-RBM3R2020-200 | 20 | 20 | 200 | 35 | 2 | RP..1003 | MS 4009A | T15 | --- | --- | --- | |
| OMV-RBM5R2020-150 | 20 | 20 | 150 | 35 | 2 | RP..1003 | MS 4009A | T15 | --- | --- | --- | |
| OMV-RBM5R2020-200 | 20 | 20 | 200 | 35 | 2 | RP..1003 | MS 4009A | T15 | --- | --- | --- | |
| OMV-RBM5R2120-150 | 21 | 20 | 150 | 25 | 2 | RP..1003 | MS 4009A | T15 | --- | --- | --- | |
| OMV-RBM5R2120-200 | 21 | 20 | 200 | 25 | 2 | RP..1003 | MS 4009A | T15 | --- | --- | --- | |
| OMV-RBM5R2525-150 | 25 | 25 | 150 | 40 | 2 | RP..1003 | MS 4009A | T15 | --- | --- | --- | |
| OMV-RBM5R2525-200 | 25 | 25 | 200 | 40 | 2 | RP..1003 | MS 4009A | T15 | --- | --- | --- | |
| OMV-RBM5R2625-150 | 26 | 25 | 150 | 30 | 2 | RP..1003 | MS 4009A | T15 | --- | --- | --- | |
| OMV-RBM5R2625-200 | 26 | 25 | 200 | 30 | 2 | RP..1003 | MS 4009A | T15 | --- | --- | --- | |
| OMV-RBM5R2525-150-10T3 | 25 | 25 | 150 | 40 | 2 | RP..10T3 | MS 3509A | T15 | --- | --- | --- | |
| OMV-RBM5R2525-200-10T3 | 25 | 25 | 200 | 40 | 2 | RP..10T3 | MS 3509A | T15 | --- | --- | --- | |
| OMV-RBM5R2525-250-10T3 | 25 | 25 | 250 | 40 | 2 | RP..10T3 | MS 3509A | T15 | --- | --- | --- | |
| OMV-RBM6R2525-150-1203 | 25 | 25 | 150 | 45 | 2 | RP..1203 | MS 4009A | T15 | --- | --- | --- | |
| OMV-RBM6R2525-200-1203 | 25 | 25 | 200 | 45 | 2 | RP..1203 | MS 4009A | T15 | --- | --- | --- | |
| OMV-RBM6R2525-250-1203 | 25 | 25 | 250 | 45 | 2 | RP..1203 | MS 4009A | T15 | --- | --- | --- | |
| OMV-RBM6R2525-150 | 25 | 25 | 150 | 45 | 2 | RP..1204 | MS 4009A | T15 | --- | --- | --- | |
| OMV-RBM6R2525-200 | 25 | 25 | 200 | 45 | 2 | RP..1204 | MS 4009A | T15 | --- | --- | --- | |
| OMV-RBM6R2525-250 | 25 | 25 | 250 | 45 | 2 | RP..1204 | MS 4009A | T15 | --- | --- | --- | |
| OMV-RBM6R2625-150 | 26 | 25 | 150 | 35 | 2 | RP..1204 | MS 4011A | T15 | --- | --- | --- | |
| OMV-RBM6R2625-200 | 26 | 25 | 200 | 35 | 2 | RP..1204 | MS 4011A | T15 | --- | --- | --- | |
| OMV-RBM6R2625-250 | 26 | 25 | 250 | 35 | 2 | RP..1204 | MS 4011A | T15 | --- | --- | --- | |
| OMV-RBM6R3232-150 | 32 | 32 | 150 | 45 | 2 | RP..1204 | MS 4011A | T15 | --- | --- | --- | |
| OMV-RBM6R3232-200 | 32 | 32 | 200 | 45 | 2 | RP..1204 | MS 4011A | T15 | --- | --- | --- | |
| OMV-RBM6R3232-150 | 32 | 32 | 150 | 45 | 3 | RP..1204 | MS 4011A | T15 | --- | --- | --- | |
| OMV-RBM6R3232-200 | 32 | 32 | 200 | 45 | 3 | RP..1204 | MS 4011A | T15 | --- | --- | --- | |
| OMV-RBM6R3232-250 | 32 | 32 | 250 | 45 | 3 | RP..1204 | MS 4011A | T15 | --- | --- | --- | |

圓刃銑刀

CORNER ROUNDING END MILLS

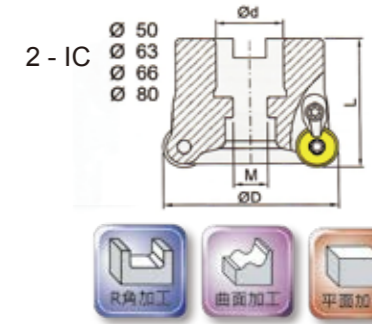
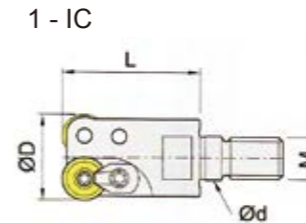

| 產品編號 1 - Item Code | 尺寸 Dimensions (mm) | | | | 刃數 Teeth | 刀片型號 Insert | Screw | Wrench | Screw | Clamp | Wrench | 牌價 Price |
|-----------------------|--------------------|------|----|-----|-------------|----------------|----------|--------|----------|----------|--------|-------------|
| | D | d | L | M | | | | | | | | |
| OMVM-RBM5R202-M10 | 20 | 10.5 | 30 | M10 | 2 | RP..1003 | MS 4009A | T15 | --- | --- | --- | |
| OMVM-RBM5R212-M10 | 21 | 10.5 | 30 | M10 | 2 | RP..1003 | MS 4009A | T15 | --- | --- | --- | |
| OMVM-RBM5R252-M12 | 25 | 12.5 | 35 | M12 | 2 | RP..1003 | MS 4009A | T15 | MS 3509A | MC35-143 | T15 | |
| OMVM-RBM5R253-M12 | 25 | 12.5 | 35 | M12 | 3 | RP..1003 | MS 4009A | T15 | --- | --- | --- | |
| OMVM-RBM5R262-M12 | 26 | 12.5 | 35 | M12 | 2 | RP..1003 | MS 4009A | T15 | --- | --- | --- | |
| OMVM-RBM5R303-M12 | 30 | 12.5 | 35 | M12 | 3 | RP..1003 | MS 4009A | T15 | --- | --- | --- | |
| OMVM-RBM5R353-M16 | 35 | 17 | 43 | M16 | 3 | RP..1003 | MS 4009A | T15 | MS 3509A | MC35-143 | T15 | |
| OMVM-RBM5R354-M16 | 35 | 17 | 43 | M16 | 4 | RP..1003 | MS 4009A | T15 | --- | --- | --- | |
| OMVM-RBM6R252-M12 | 25 | 12.5 | 35 | M12 | 2 | RP..1204 | MS 4009A | T15 | MS 3509A | MC35-143 | T15 | |
| OMVM-RBM6R262-M12 | 26 | 12.5 | 35 | M12 | 2 | RP..1204 | MS 4011A | T15 | MS 3509A | MC35-143 | T15 | |

| 產品編號 2 - Item Code | 尺寸 Dimensions (mm) | | | | 刃數 Teeth | 刀片型號 Insert | Screw | Wrench | Screw | Clamp | Wrench | 牌價 Price |
|-----------------------|--------------------|-------|----|----|-------------|----------------|----------|--------|-------|-------|--------|-------------|
| | D | d | L | M | | | | | | | | |
| OFV-RP6R50*220 | 50 | 22.0 | 50 | 13 | 4 | RP..1204 | MS 4011A | T15 | --- | --- | --- | |
| OFV-RP6R50*254 | 50 | 25.4 | 50 | 13 | 4 | RP..1204 | MS 4011A | T15 | --- | --- | --- | |
| OFV-RP6R63*254 | 63 | 25.4 | 50 | 13 | 5 | RP..1204 | MS 4011A | T15 | --- | --- | --- | |
| OFV-RP6R66*254 | 66 | 25.4 | 50 | 13 | 5 | RP..1204 | MS 4011A | T15 | --- | --- | --- | |
| OFV-RP6R80*254 | 80 | 25.4 | 50 | 13 | 6 | RP..1204 | MS 4011A | T15 | --- | --- | --- | |
| OFV-RP6R100*3175 | 100 | 31.75 | 50 | 13 | 6 | RP..1204 | MS 4011A | T15 | --- | --- | --- | |

| 刀片型號 Description | 刀片形狀 Insert Shape | 尺寸 Dimensions (mm) | | | 牌價 Price |
|---------------------|----------------------|--------------------|------|-----|-------------|
| | | lc | S | d1 | |
| RPMT0602 | | 6 | 2.38 | 2.5 | VMM415 |
| RPMT08T2 | | 8 | 2.78 | 2.9 | VMM415 |
| RPMT10T3 | | 10 | 3.97 | 3.9 | VMM415 |
| RPMT1204 | | 12 | 4.76 | 4.4 | VMM415 |
| RPMW1003 | | 10 | 3.18 | 4.4 | VMM415 |

(A) 銑刀
ENDMILLS
(B) 鑽頭
DRILLS
(C) 絞刀
REAMERS
(D) 絲攻
TAPS
(E) 刀桿/刀盤
MILLING CUTTERS
(F) 刀片
INSERTS

(A) 銑刀
ENDMILLS
(B) 鑽頭
DRILLS
(C) 絞刀
REAMERS
(D) 絲攻
TAPS
(E) 刀桿/刀盤
MILLING CUTTERS
(F) 刀片
INSERTS

圓刃銑刀

CORNER ROUNDING END MILLS

(A) 銑刀
ENDMILLS

(B) 鑽頭
DRILLS

(C) 絞刀
REAMERS

(D) 絲攻
TAPS

(E) 刀桿/刀盤
MILLING CUTTERS

(F) 刀片
INSERTS

| 產品編號 Item Code | 尺寸 Dimensions (mm) | | | | 刃數 Teeth | 刀片 型號 Insert | Screw | Wrench | Screw | Clamp | Wrench | 牌價 Price | | | | | | |
|--------------------------|--------------------|----|-----|----|-------------|--------------------|-------------|--------|-------------|--------------|--------------|-------------|-----|-------------|--------------|-----|-----|--|
| | D | d | L | L1 | | | | | | | | | | | | | | |
| OMV-RAM5R2020-150-1003 | 20 | 20 | 150 | 40 | 2 | RD.. 1003 | MS 3507A | T15 | --- | --- | --- | | | | | | | |
| OMV-RAM5R2020-200-1003 | 20 | 20 | 200 | 40 | 2 | | | | | | | | | | | | | |
| OMV-RAM5R2120-150-1003 | 21 | 20 | 150 | 25 | 2 | | | | | | | | | | | | | |
| OMV-RAM5R2120-200-1003 | 21 | 20 | 200 | 25 | 2 | | | | | | | | | | | | | |
| OMV-RAM5R2525-150-1003 | 25 | 25 | 150 | 40 | 3 | | | | | | | | | | | | | |
| OMV-RAM5R2525-200-1003 | 25 | 25 | 200 | 40 | 3 | | | | | | | | | | | | | |
| OMV-RAM5R2525-250-1003 | 25 | 25 | 250 | 40 | 3 | | | | | | | | | | | | | |
| OMV-RAM5R2625-150-1003 | 26 | 25 | 150 | 25 | 3 | | | | | | | | | | | | | |
| OMV-RAM5R2625-200-1003 | 26 | 25 | 200 | 25 | 3 | | | | | | | | | | | | | |
| OMV-RAM5R2625-250-1003 | 26 | 25 | 250 | 25 | 3 | | | | | | | | | | | | | |
| OMV-RAM5R3025-150-1003 | 30 | 25 | 150 | 25 | 3 | RD.. 1003 | MS 3509A | T15 | --- | --- | | | | | | | | |
| OMV-RAM5R3025-200-1003 | 30 | 25 | 200 | 25 | 3 | | | | | | | | | | | | | |
| OMV-RAM5R3025-250-1003 | 30 | 25 | 250 | 25 | 3 | | | | | | | | | | | | | |
| OMV-RAM5R3232-150-1003 | 32 | 32 | 150 | 40 | 3 | | | | | | | | | | | | | |
| OMV-RAM5R3232-200-1003 | 32 | 32 | 200 | 40 | 3 | | | | | | | | | | | | | |
| OMV-RAM5R3232-250-1003 | 32 | 32 | 250 | 40 | 3 | | | | | | | | | | | | | |
| OMV-RAM5R3232-300-1003 | 32 | 32 | 300 | 40 | 3 | | | | | | | | | | | | | |
| OMV-RAM5R3532-150-1003 | 35 | 32 | 150 | 35 | 3 | | | | | | | | | | | | | |
| OMV-RAM5R3532-200-1003 | 35 | 32 | 200 | 35 | 3 | | | | | | | | | | | | | |
| OMV-RAM5R3532-250-1003 | 35 | 32 | 250 | 35 | 3 | | | | | | RD.. 1003 | MS 3509A | --- | MS 3509A | MC35 -143 | T15 | | |
| OMV-RAM5R3532-300-1003 | 35 | 32 | 300 | 35 | 3 | | | | | | | | | | | | | |
| OMV-RAM5R3532-150-4-1003 | 35 | 32 | 150 | 35 | 4 | | | | | | | | | | | | | |
| OMV-RAM5R3532-200-4-1003 | 35 | 32 | 200 | 35 | 4 | | | | | | | | | | | | | |
| OMV-RAM5R3532-250-4-1003 | 35 | 32 | 250 | 35 | 4 | | | | | | | | | | | | | |
| OMV-RAM5R3532-300-4-1003 | 35 | 32 | 300 | 35 | 4 | | | | | | | | | | | | | |
| OMV-RAM5R2525-150 | 25 | 25 | 150 | 45 | 2 | RD.. 10T3 | MS 4009B | T15 | MS 3509A | MC35 -143 | | | | | | | T15 | |
| OMV-RAM5R2525-200 | 25 | 25 | 200 | 45 | 2 | | | | | | | | | | | | | |
| OMV-RAM5R2525-250 | 25 | 25 | 250 | 45 | 2 | | | | | | | | | | | | | |
| OMV-RAM5R2625-150 | 26 | 25 | 150 | 30 | 2 | | | | | | | | | | | | | |
| OMV-RAM5R2625-200 | 26 | 25 | 200 | 30 | 2 | | | | | | | | | | | | | |
| OMV-RAM5R2625-250 | 26 | 25 | 250 | 30 | 2 | | | | | | | | | | | | | |

圓刃銑刀

CORNER ROUNDING END MILLS

(A) 銑刀
ENDMILLS

(B) 鑽頭
DRILLS

(C) 絞刀
REAMERS

(D) 絲攻
TAPS

(E) 刀桿/刀盤
MILLING CUTTERS

(F) 刀片
INSERTS

| 產品編號 Item Code | 尺寸 Dimensions (mm) | | | | 刃數 Teeth | 刀片 型號 Insert | Screw | Wrench | Screw | Clamp | Wrench | 牌價 Price | | | | | | |
|---------------------|--------------------|----|-----|----|-------------|--------------------|-------------|--------|-------------|--------------|--------|--------------|-------------|-----|-------------|--------------|-----|--|
| | D | d | L | L1 | | | | | | | | | | | | | | |
| OMV-RAM5R3025-150 | 30 | 25 | 150 | 30 | 2 | RD.. 10T3 | MS 4009B | T15 | MS 3509A | MC35 -143 | T15 | | | | | | | |
| OMV-RAM5R3025-200 | 30 | 25 | 200 | 30 | 2 | | | | | | | | | | | | | |
| OMV-RAM5R3025-250 | 30 | 25 | 250 | 30 | 2 | | | | | | | | | | | | | |
| OMV-RAM5R3025-150-3 | 30 | 25 | 150 | 30 | 3 | | | | | | | | | | | | | |
| OMV-RAM5R3025-200-3 | 30 | 25 | 200 | 30 | 3 | | | | | | | | | | | | | |
| OMV-RAM5R3025-250-3 | 30 | 25 | 250 | 30 | 3 | | | | | | | | | | | | | |
| OMV-RAM5R3232-150 | 32 | 32 | 150 | 45 | 3 | | | | | | | | | | | | | |
| OMV-RAM5R3232-200 | 32 | 32 | 200 | 45 | 3 | | | | | | | | | | | | | |
| OMV-RAM5R3232-250 | 32 | 32 | 250 | 45 | 3 | | | | | | | | | | | | | |
| OMV-RAM5R3232-300 | 32 | 32 | 300 | 45 | 3 | | | | | | | | | | | | | |
| OMV-RAM5R3532-150 | 35 | 32 | 150 | 35 | 3 | | | | | | | | | | | | | |
| OMV-RAM5R3532-200 | 35 | 32 | 200 | 35 | 3 | | | | | | | | | | | | | |
| OMV-RAM5R3532-250 | 35 | 32 | 250 | 35 | 3 | | | | | | | | | | | | | |
| OMV-RAM5R3532-300 | 35 | 32 | 300 | 35 | 3 | | | | | | | | | | | | | |
| OMV-RAM5R4032-150 | 40 | 32 | 150 | 35 | 3 | | | | | | | | | | | | | |
| OMV-RAM5R4032-200 | 40 | 32 | 200 | 35 | 3 | | | | | | | | | | | | | |
| OMV-RAM5R4032-250 | 40 | 32 | 250 | 35 | 3 | | | | | | | | | | | | | |
| OMV-RAM5R4032-300 | 40 | 32 | 300 | 35 | 3 | | | | | | | | | | | | | |
| OMV-RAM6R2525-100 | 25 | 25 | 100 | 45 | 2 | | | | | | | RD.. 1204 | MS 4009A | T15 | MS 3509A | MC35 -143 | T15 | |
| OMV-RAM6R2525-150 | 25 | 25 | 150 | 45 | 2 | | | | | | | | | | | | | |
| OMV-RAM6R2525-200 | 25 | 25 | 200 | 45 | 2 | | | | | | | | | | | | | |

| 刀片型號 Description | 刀片形狀 Insert Shape | 尺寸 Dimensions (mm) | | | 牌價 Price |
|---------------------|----------------------|--------------------|------|-----|-------------|
| | | lc | S | d1 | |
| RDMW0501 | | 5 | 1.5 | 1.9 | |
| RDMT0602 | | 6 | 2.38 | 2.5 | |
| RDHT0702 | | 7 | 2.38 | 2.8 | |
| RDMT0802 | | 8 | 2.38 | 3.4 | |
| RDHT1003 | | 10 | 3.18 | 4.4 | |
| RDMT10T3 | | 10 | 3.97 | 4.5 | |
| RDMT1204 | | 12 | 4.76 | 4.5 | |

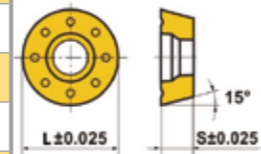

圓刃銑刀

CORNER ROUNDING END MILLS

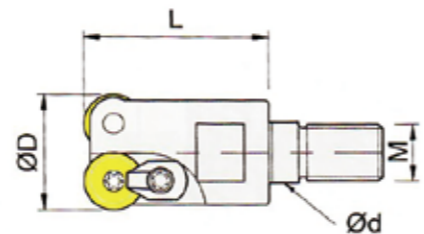

| 產品編號 Item Code | 尺寸 Dimensions (mm) | | | | 刃數 Teeth | 刀片 型號 Insert | Screw | Wrench | Screw | Clamp | Wrench | 牌價 Price | | | | | | | |
|---------------------|--------------------|------|----|-----|-------------|--------------------|-------------|--------|-------------|--------------|--------|-------------|--------------|-------------|-----|-----|-----|-----|--|
| | D | d | L | M | | | | | | | | | | | | | | | |
| OMVM-RAM2.5R102-M5 | 10 | 5.5 | 16 | M5 | 2 | RD.. 0501 | MS 1804A | T06 | --- | --- | --- | | | | | | | | |
| OMVM-RAM2.5R112-M5 | 11 | 5.5 | 16 | M5 | 2 | | | | | | | | | | | | | | |
| OMVM-RAM2.5R122-M6 | 12 | 6.5 | 18 | M6 | 2 | | | | | | | | | | | | | | |
| OMVM-RAM2.5R123-M6 | 12 | 6.5 | 18 | M6 | 3 | | | | | | | | | | | | | | |
| OMVM-RAM2.5R132-M6 | 13 | 6.5 | 18 | M6 | 2 | | | | | | | | | | | | | | |
| OMVM-RAM2.5R133-M6 | 13 | 6.5 | 18 | M6 | 3 | | | | | | | | | | | | | | |
| OMVM-RAM2.5R133-M6 | 13 | 8.5 | 18 | M6 | 3 | | | | | | | | | | | | | | |
| OMVM-RAM2.5R174-M8 | 17 | 8.5 | 23 | M8 | 4 | | | | | | | | | | | | | | |
| OMVM-RAM3R162-M8 | 16 | 8.5 | 23 | M8 | 2 | | | | | | | | RD.. 0602 | MS 2506S | T09 | --- | --- | --- | |
| OMVM-RAM3R172-M8 | 17 | 8.5 | 23 | M8 | 2 | | | | | | | | | | | | | | |
| OMVM-RAM3R202-M10 | 20 | 10.5 | 30 | M10 | 2 | | | | | | | | | | | | | | |
| OMVM-RAM3R212-M10 | 21 | 10.5 | 30 | M10 | 2 | RD.. 0702 | MS 2506S | T09 | MS 3509A | MC35 -143 | T15 | | | | | | | | |
| OMVM-RAM3.5R162-M8 | 16 | 8.5 | 23 | M8 | 2 | | | | | | | | | | | | | | |
| OMVM-RAM3.5R172-M8 | 17 | 8.5 | 23 | M8 | 2 | | | | | | | | | | | | | | |
| OMVM-RAM3.5R202-M10 | 20 | 10.5 | 30 | M10 | 2 | RD.. 0802 | MS 3006B | T09 | --- | --- | --- | | | | | | | | |
| OMVM-RAM3.5R212-M10 | 21 | 10.5 | 30 | M10 | 2 | | | | | | | | | | | | | | |
| OMVM-RAM4R162-M8 | 16 | 8.5 | 23 | M8 | 2 | | | | | | | | | | | | | | |
| OMVM-RAM4R172-M8 | 17 | 8.5 | 23 | M8 | 2 | RD.. 0802 | MS 3008B | T09 | MS 3509A | MC35 -143 | T15 | | | | | | | | |
| OMVM-RAM4R202-M10 | 20 | 10.5 | 30 | M10 | 2 | | | | | | | | | | | | | | |
| OMVM-RAM4R212-M10 | 21 | 10.5 | 30 | M10 | 2 | | | | | | | | | | | | | | |
| OMVM-RAM4R253-M12 | 25 | 12.5 | 35 | M12 | 3 | | | | | | | | | | | | | | |

圓刃銑刀

CORNER ROUNDING END MILLS

| 產品編號 Item Code | 尺寸 Dimensions (mm) | | | | 刃數 Teeth | 刀片 型號 Insert | Screw | Wrench | Screw | Clamp | Wrench | 牌價 Price |
|-------------------|--------------------|------|----|-----|-------------|--------------------|-------------|--------|-------|-------|--------|-------------|
| | D | d | L | L1 | | | | | | | | |
| OMVM-RAM5R202-M10 | 20 | 10.5 | 30 | M10 | 2 | RD.. 10T3 | MS 4008B | T15 | --- | --- | --- | |
| OMVM-RAM5R212-M10 | 21 | 10.5 | 30 | M10 | 2 | | | | | | | |
| OMVM-RAM5R252-M12 | 25 | 12.5 | 35 | M12 | 2 | | | | | | | |
| OMVM-RAM5R253-M12 | 25 | 12.5 | 35 | M12 | 3 | | | | | | | |
| OMVM-RAM5R262-M12 | 26 | 12.5 | 35 | M12 | 2 | | | | | | | |
| OMVM-RAM5R263-M12 | 26 | 12.5 | 35 | M12 | 3 | | | | | | | |
| OMVM-RAM5R302-M16 | 30 | 17 | 43 | M16 | 2 | | | | | | | |
| OMVM-RAM5R323-M16 | 32 | 17 | 43 | M16 | 3 | | | | | | | |
| OMVM-RAM5R353-M16 | 35 | 17 | 43 | M16 | 3 | | | | | | | |
| OMVM-RAM5R354-M16 | 35 | 17 | 43 | M16 | 4 | | | | | | | |
| OMVM-RAM5R404-M16 | 40 | 17 | 43 | M16 | 4 | | | | | | | |
| OMVM-RAM5R424-M16 | 42 | 17 | 43 | M16 | 4 | | | | | | | |
| OMVM-RAM5R425-M16 | 42 | 17 | 43 | M16 | 5 | RD.. 1204 | MS 4009B | T15 | --- | --- | --- | |
| OMVM-RAM6R252-M12 | 25 | 12.5 | 35 | M12 | 2 | | | | | | | |
| OMVM-RAM6R353-M16 | 35 | 17 | 43 | M16 | 3 | | | | | | | |
| OMVM-RAM6R404-M16 | 40 | 17 | 43 | M16 | 4 | | | | | | | |
| OMVM-RAM6R424-M16 | 42 | 17 | 43 | M16 | 4 | | | | | | | |

| 刀片型號 Description | 刀片形狀 Insert Shape | 尺寸 Dimensions (mm) | | | 牌價 Price | | |
|---------------------|----------------------|--------------------|------|-----|----------|---------|---------|
| | | lc | S | d1 | VMX1020 | VMH4020 | WMH9020 |
| RDMW0501 | | 5 | 1.5 | 1.9 | | | |
| RDMT0602 | | 6 | 2.38 | 2.5 | | | |
| RDHT0702 | | 7 | 2.38 | 2.8 | | | |
| RDMT0802 | | 8 | 2.38 | 3.4 | | | |
| RDMT10T3 | | 10 | 3.97 | 4.5 | | | |
| RDMT1204 | | 12 | 4.76 | 4.5 | | | |

(A) 銑刀
ENDMILLS
(B) 鑽頭
DRILLS
(C) 絞刀
REAMERS
(D) 絲攻
TAPS
(E) 刀桿/刀盤
MILLING CUTTERS
(F) 刀片
INSERTS

(A) 銑刀
ENDMILLS
(B) 鑽頭
DRILLS
(C) 絞刀
REAMERS
(D) 絲攻
TAPS
(E) 刀桿/刀盤
MILLING CUTTERS
(F) 刀片
INSERTS

球型精銑刀

BALL PRECISION CUTTERS

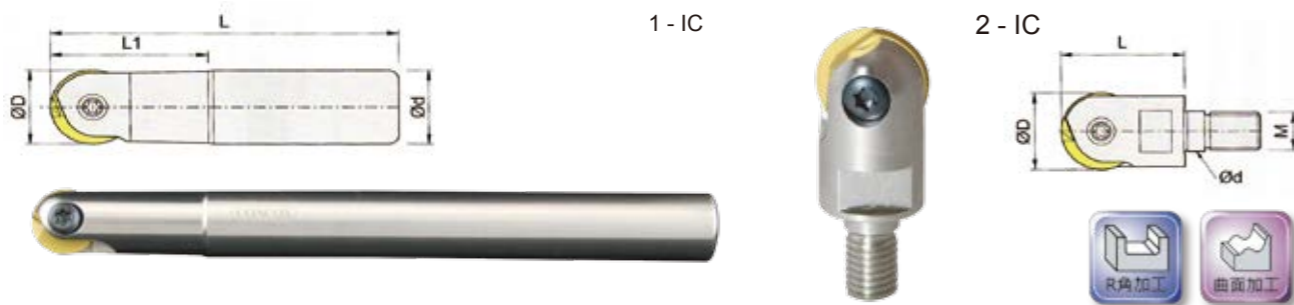

| 產品編號 1 - Item Code | 尺寸 Dimensions (mm) | | | | 刃數 Teeth | 刀片型號 Insert | Screw | Wrench | 牌價 Price |
|-----------------------|--------------------|----|-----|----|-------------|----------------|---------|--------|-------------|
| | D | d | L | L1 | | | | | |
| OMV-CR0808-100 | 8 | 8 | 100 | 20 | 1 | P3202-D08 | MGR3008 | T08 | |
| OMV-CR0810-100 | 8 | 10 | 100 | 35 | 1 | | | | |
| OMV-CR1010-100 | 10 | 10 | 100 | 25 | 1 | P3202-D10 | MGR4010 | T15 | |
| OMV-CR1012-150 | 10 | 12 | 150 | 36 | 1 | | | | |
| OMV-CR1212-150 | 12 | 12 | 150 | 32 | 1 | P3202-D12 | MGR5012 | T20 | |
| OMV-CR1216-200 | 12 | 16 | 200 | 58 | 1 | | | | |
| OMV-CR1616-150 | 16 | 16 | 150 | 36 | 1 | | | | |
| OMV-CR1616-200 | 16 | 16 | 200 | 36 | 1 | P3202-D16 | MGR5016 | T20 | |
| OMV-CR1620-200 | 16 | 20 | 200 | 65 | 1 | | | | |
| OMV-CR2020-150 | 20 | 20 | 150 | 45 | 1 | | | | |
| OMV-CR2020-200 | 20 | 20 | 200 | 45 | 1 | P3202-D20 | MGR5020 | T20 | |
| OMV-CR2025-200 | 20 | 25 | 200 | 76 | 1 | | | | |
| OMV-CR2025-250 | 20 | 25 | 250 | 76 | 1 | | | | |
| OMV-CR2525-200 | 25 | 25 | 200 | 45 | 1 | | | | |
| OMV-CR2525-250 | 25 | 25 | 250 | 45 | 1 | | | | |
| OMV-CR2532-200 | 25 | 32 | 200 | 98 | 1 | P3202-D25 | MGR6025 | T30 | |
| OMV-CR2532-250 | 25 | 32 | 250 | 98 | 1 | | | | |
| OMV-CR2532-300 | 25 | 32 | 300 | 98 | 1 | | | | |
| OMV-CR3032-200 | 30 | 32 | 200 | 50 | 1 | | | | |
| OMV-CR3032-250 | 30 | 32 | 250 | 50 | 1 | P3202-D30 | MGR8030 | T30 | |
| OMV-CR3032-300 | 30 | 32 | 300 | 50 | 1 | | | | |

| 產品編號 2 - Item Code | 尺寸 Dimensions (mm) | | | | 刃數 Teeth | 刀片型號 Insert | Screw | Wrench | 牌價 Price |
|-----------------------|--------------------|------|----|-----|-------------|----------------|---------|--------|-------------|
| | D | d | L | M | | | | | |
| OMVM-CR080M04 | 8 | 4.5 | 16 | M4 | 1 | WGRMT-D08 | MGR3008 | T08 | |
| OMVM-CR080M05 | 8 | 5.5 | 16 | M5 | 1 | | | | |
| OMVM-CR100M05 | 10 | 5.5 | 20 | M5 | 1 | WGRMT-D10 | MGR4010 | T15 | |
| OMVM-CR120M06 | 12 | 6.5 | 22 | M6 | 1 | | | | |
| OMVM-CR120M08 | 12 | 8.5 | 30 | M8 | 1 | WGRMT-D12 | MGR5012 | T20 | |
| OMVM-CR160M08 | 16 | 8.5 | 28 | M8 | 1 | WGRMT-D16 | MGR5016 | T20 | |
| OMVM-CR200M10 | 20 | 10.5 | 30 | M10 | 1 | WGRMT-D20 | MGR5020 | T20 | |
| OMVM-CR250M12 | 25 | 12.5 | 40 | M12 | 1 | WGRMT-D25 | MGR6025 | T30 | |
| OMVM-CR300M16 | 30 | 17 | 43 | M16 | 1 | WGRMT-D30 | MGR8030 | T30 | |

R角精銑刀

RADIUS PRECISION CUTTERS

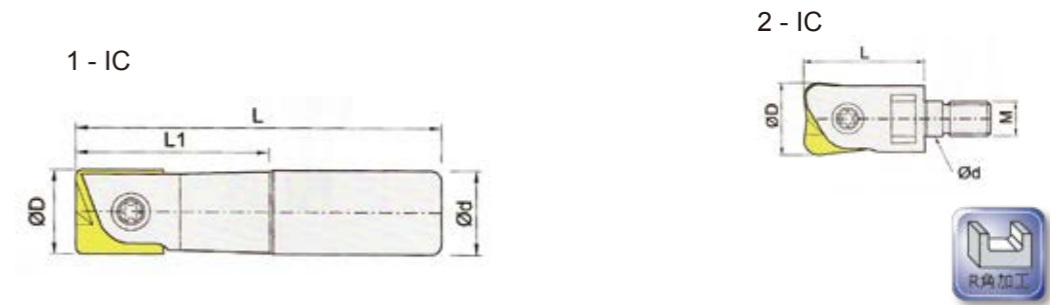

| 產品編號 1 - Item Code | 尺寸 Dimensions (mm) | | | | 刃數 Teeth | 刀片型號 Insert | Screw | Wrench | 牌價 Price |
|-----------------------|--------------------|----|-----|----|-------------|----------------|---------|--------|-------------|
| | D | d | L | L1 | | | | | |
| OMV-GWV12-S12-150 | 12 | 12 | 150 | 30 | 1 | WPV 12-N-S1st | MGR5012 | T20 | |
| OMV-GWV16-S16-150 | 16 | 16 | 150 | 35 | 1 | | | | |
| OMV-GWV16-S16-200 | 16 | 16 | 200 | 35 | 1 | WPV 16-N-S1st | MGR5016 | T20 | |
| OMV-GWV20-S20-150 | 20 | 20 | 150 | 40 | 1 | | | | |
| OMV-GWV20-S20-200 | 20 | 20 | 200 | 40 | 1 | WPV 20-N-S1st | MGR5020 | T20 | |

| 產品編號 2 - Item Code | 尺寸 Dimensions (mm) | | | | 刃數 Teeth | 刀片型號 Insert | Screw | Wrench | 牌價 Price |
|-----------------------|--------------------|------|----|-----|-------------|----------------|---------|--------|-------------|
| | D | d | L | M | | | | | |
| OMVM-GWV20-MD18 | 20 | 10.5 | 30 | M10 | 1 | WPV 20-N-S1st | MGR5020 | T20 | |
| OMVM-GWV25-MD23 | 25 | 12.5 | 40 | M12 | 1 | WPV 25-N-S1st | MGR6025 | T30 | |

| 刀片型號 Description | 刀片形狀 Insert Shape | 尺寸 Dimensions (mm) | | | | 牌價 Price | | |
|---------------------|----------------------|--------------------|-----|----|------|----------|-----|-----|
| | | D +0-0.03 | S | d1 | L | VMX | VMH | VMW |
| P3202-D08 | | 8 | 2.0 | 3 | 9.5 | | | |
| P3202-D10 | | 10 | 2.5 | 4 | 11.5 | | | |
| P3202-D12 | | 12 | 2.5 | 5 | 12.0 | | | |
| P3202-D16 | | 16 | 3.0 | 5 | 14.0 | | | |
| P3202-D20 | | 20 | 3.0 | 5 | 16.0 | | | |
| P3202-D25 | | 25 | 4.0 | 6 | 21.5 | | | |
| P3202-D30 | | 30 | 5.0 | 8 | 25.5 | | | |

| 刀片型號 Description | 刀片形狀 Insert Shape | 尺寸 Dimensions (mm) | | | | 牌價 Price | | |
|---------------------|----------------------|--------------------|-----|----|-----|----------|-----|-----|
| | | D +0-0.03 | S | d1 | Re | VMX | VMH | VMW |
| WPV 12-N-S1st | | 12 | 2.5 | 5 | 1.0 | | | |
| WPV 16-N-S1st | | 16 | 3.0 | 5 | 1.3 | | | |
| WPV 20-N-S1st | | 20 | 3.0 | 5 | 1.6 | | | |
| WPV 25-N-S1st | | 25 | 4.0 | 6 | 2.0 | | | |

(A) 銑刀
ENDMILLS
(B) 鑽頭
DRILLS
(C) 絞刀
REAMERS
(D) 絲攻
TAPS
(E) 刀桿/刀盤
MILLING CUTTERS
(F) 刀片
INSERTS

(A) 銑刀
ENDMILLS
(B) 鑽頭
DRILLS
(C) 絞刀
REAMERS
(D) 絲攻
TAPS
(E) 刀桿/刀盤
MILLING CUTTERS
(F) 刀片
INSERTS

球型精銑刀

BAL L PRECISION CUTTERS

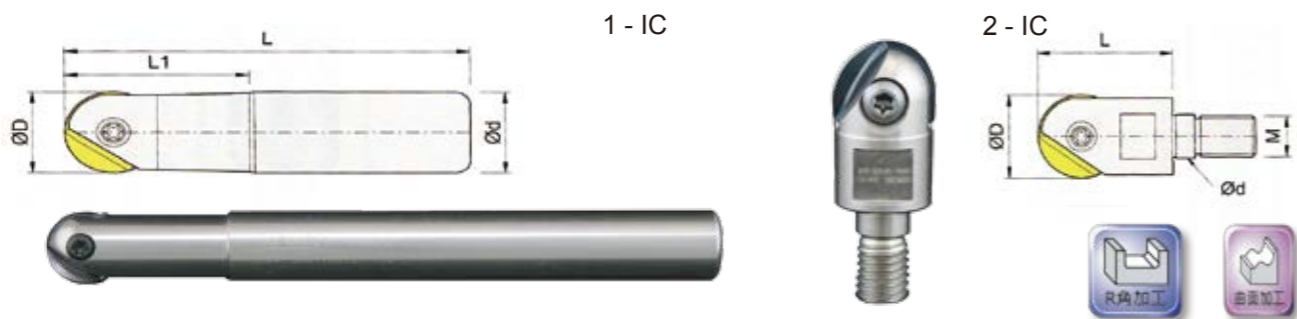

| 產品編號 1 - Item Code | 尺寸 Dimensions (mm) | | | | 刃數 Teeth | 刀片型號 Insert | Screw | Wrench | 牌價 Price |
|-----------------------|--------------------|----|-----|----|-------------|----------------------------------|---------|--------|-------------|
| | D | d | L | L1 | | | | | |
| OMV-SRFH0808-100 | 8 | 8 | 100 | 20 | 1 | SRFT(K033) PPH-080 BNM-050 | DVF6240 | T07 | |
| OMV-SRFH0810-100 | 8 | 10 | 100 | 35 | 1 | PPH-100 BNM-100 | DVF6241 | T08 | |
| OMV-SRFH1010-100 | 10 | 10 | 100 | 25 | 1 | | | | |
| OMV-SRFH1012-100 | 10 | 12 | 100 | 36 | 1 | PPH-120 BNM-120 | DVF6242 | T10 | |
| OMV-SRFH1212-150 | 12 | 12 | 150 | 32 | 1 | | | | |
| OMV-SRFH1216-200 | 12 | 16 | 200 | 58 | 1 | PPH-160 BNM-160 | DVF6244 | T15 | |
| OMV-SRFH1616-150 | 16 | 16 | 150 | 36 | 1 | | | | |
| OMV-SRFH1616-200 | 16 | 16 | 200 | 36 | 1 | PPH-200 BNM-200 | DVF6246 | T20 | |
| OMV-SRFH1620-200 | 16 | 20 | 200 | 65 | 1 | | | | |
| OMV-SRFH2020-150 | 20 | 20 | 150 | 45 | 1 | PPH-250 BNM-250 | DVF6247 | T30 | |
| OMV-SRFH2020-200 | 20 | 20 | 200 | 45 | 1 | | | | |
| OMV-SRFH2025-200 | 20 | 25 | 200 | 76 | 1 | PPH-250 BNM-250 | DVF6247 | T30 | |
| OMV-SRFH2025-250 | 20 | 25 | 250 | 76 | 1 | | | | |
| OMV-SRFH2525-200 | 25 | 25 | 200 | 45 | 1 | PPH-250 BNM-250 | DVF6247 | T30 | |
| OMV-SRFH2525-250 | 25 | 25 | 250 | 45 | 1 | | | | |
| OMV-SRFH2532-200 | 25 | 32 | 200 | 98 | 1 | PPH-250 BNM-250 | DVF6247 | T30 | |
| OMV-SRFH2532-250 | 25 | 32 | 250 | 98 | 1 | | | | |
| OMV-SRFH2532-300 | 25 | 32 | 300 | 98 | 1 | | | | |

| 產品編號 2 - Item Code | 尺寸 Dimensions (mm) | | | | 刃數 Teeth | 刀片型號 Insert | Screw | Wrench | 牌價 Price |
|-----------------------|--------------------|------|----|-----|-------------|-----------------|---------|--------|-------------|
| | D | d | L | M | | | | | |
| OMVM-SRFH08M04 | 8 | 4.5 | 16 | M4 | 1 | PPH-080/BMM-080 | DVF6240 | T07 | |
| OMVM-SRFH10M05 | 10 | 5.5 | 20 | M5 | 1 | PPH-100/BMM-100 | DVF6241 | T08 | |
| OMVM-SRFH12M06 | 12 | 6.5 | 22 | M6 | 1 | PPH-120/BMM-120 | DVF6242 | T10 | |
| OMVM-SRFH16M08 | 16 | 8.5 | 28 | M8 | 1 | PPH-160/BMM-160 | DVF6244 | T15 | |
| OMVM-SRFH20M10 | 20 | 10.5 | 30 | M10 | 1 | PPH-200/BMM-200 | DVF6246 | T20 | |
| OMVM-SRFH25M12 | 25 | 12.5 | 40 | M12 | 1 | PPH-250/BMM-250 | DVF6247 | T30 | |

R角精銑刀

RADIUS PRECISION CUTTERS

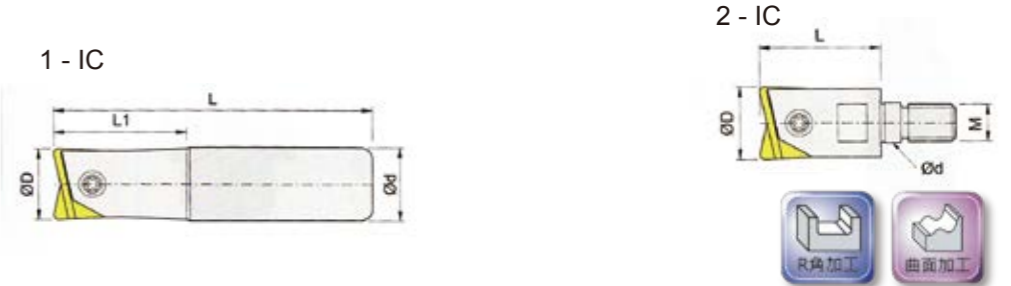

| 產品編號 1 - Item Code | 尺寸 Dimensions (mm) | | | | 刃數 Teeth | 刀片型號 Insert | Screw | Wrench | 牌價 Price |
|-----------------------|--------------------|----|-----|----|-------------|----------------|---------|--------|-------------|
| | D | d | L | L1 | | | | | |
| OMV-PPHT12-S12-150 | 12 | 12 | 150 | 32 | 1 | PPHT-120 | DVF6242 | T10 | |
| OMV-PPHT16-S16-150 | 16 | 16 | 150 | 36 | 1 | PPHT-160 | DVF6244 | T15 | |
| OMV-PPHT16-S16-200 | 16 | 16 | 200 | 36 | 1 | PPHT-160 | DVF6244 | T15 | |
| OMV-PPHT20-S20-150 | 20 | 20 | 150 | 45 | 1 | PPHT-200 | DVF6246 | T20 | |
| OMV-PPHT20-S20-200 | 20 | 20 | 200 | 45 | 1 | PPHT-200 | DVF6246 | T20 | |

| 產品編號 2 - Item Code | 尺寸 Dimensions (mm) | | | | 刃數 Teeth | 刀片型號 Insert | Screw | Wrench | 牌價 Price |
|-----------------------|--------------------|------|----|-----|-------------|----------------|---------|--------|-------------|
| | D | d | L | M | | | | | |
| OMVM-PPHT12-MD11 | 12 | 6.5 | 22 | M6 | 1 | PPHT-120 | DVF6242 | T10 | |
| OMVM-PPHT16-MD14 | 16 | 8.5 | 28 | M8 | 1 | PPHT-160 | DVF6244 | T15 | |
| OMVM-PPHT20-MD18 | 20 | 10.5 | 30 | M10 | 1 | PPHT-200 | DVF6246 | T20 | |

| 刀片型號 Description | 刀片形狀 Insert Shape | 尺寸 Dimensions (mm) | | | | 牌價 Price | |
|---------------------|----------------------|--------------------|-----|------|------|----------|-----|
| | | D | S | L | Re | VMX | VMD |
| (BNM/SRHT)PPH-080 | | 8 | 2.4 | 7.0 | 4.0 | | |
| PPH-100 | | 10 | 2.6 | 8.5 | 5.0 | | |
| PPH-120 | | 12 | 3.0 | 10.0 | 6.0 | | |
| PPH-160 | | 16 | 4.0 | 12.0 | 8.0 | | |
| PPH-200 | | 20 | 5.0 | 15.0 | 10.0 | | |
| PPH-250 | | 25 | 6.0 | 19.0 | 12.5 | | |
| PPH-300 | | 30 | 6.0 | 19.0 | 12.5 | | |

| 刀片型號 Description | 刀片形狀 Insert Shape | 尺寸 Dimensions (mm) | | | | 牌價 Price | |
|---------------------|----------------------|--------------------|-----|----|-----|----------|-----|
| | | D | S | L | Re | VMX | VMD |
| PPHT-120 | | 12 | 3.0 | 10 | 0.8 | | |
| PPHT-160 | | 16 | 4.0 | 12 | 1.0 | | |
| PPHT-200 | | 20 | 5.0 | 15 | 1.6 | | |
| SUFT12R10 | | 12 | 3.0 | 10 | 1.0 | | |
| SUFT16R10 | | 16 | 4.0 | 12 | 2.0 | | |
| SUFT20R15 | | 20 | 5.0 | 15 | 3.0 | | |

(A) 銑刀
ENDMILLS

(B) 鑽頭
DRILLS

(C) 絞刀
REAMERS

(D) 絲攻
TAPS

(E) 刀桿/刀盤
MILLING CUTTERS

(F) 刀片
INSERTS

(A) 銑刀
ENDMILLS

(B) 鑽頭
DRILLS

(C) 絞刀
REAMERS

(D) 絲攻
TAPS

(E) 刀桿/刀盤
MILLING CUTTERS

(F) 刀片
INSERTS

ABPF 球型精銑刀

ABPF BAL L PRECISION CUTTERS

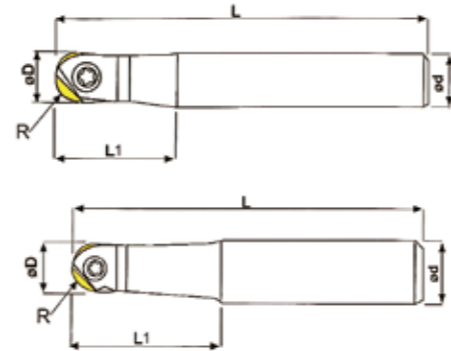

| 產品編號 Item Code | 尺寸 Dimensions (mm) | | | | | 刀片型號 Insert | Screw | Wrench | 牌價 Price |
|-------------------|--------------------|------|----|-----|-----|----------------|-------|--------|-------------|
| | D | R | d | L | L1 | | | | |
| OMV-ABPF0812-120 | 08 | 4 | 12 | 120 | 30 | ZPFG080 | 5008F | T8 | |
| OMV-ABPF0812-150 | | | 12 | 150 | 40 | | | | |
| OMV-ABPF1010-115 | 10 | 5 | 10 | 115 | 30 | ZPFG100 | 5010F | T10 | |
| OMV-ABPF1012-120 | | | 12 | 120 | 30 | | | | |
| OMV-ABPF1012-150 | | | 12 | 150 | 40 | | | | |
| OMV-ABPF1016-180 | | | 16 | 180 | 50 | | | | |
| OMV-ABPF1212-150 | 12 | 6 | 12 | 150 | 40 | ZPFG120 | 5012F | T20 | |
| OMV-ABPF1216-160 | | | 16 | 160 | 50 | | | | |
| OMV-ABPF1216-200 | | | 16 | 200 | 60 | | | | |
| OMV-ABPF1616-160 | 16 | 8 | 16 | 160 | 40 | ZPFG160 | 5016F | T20 | |
| OMV-ABPF1616-200 | | | 16 | 200 | 40 | | | | |
| OMV-ABPF1620-180 | | | 20 | 180 | 60 | | | | |
| OMV-ABPF2020-170 | 20 | 10 | 20 | 170 | 40 | ZPFG200 | 5020F | T25 | |
| OMV-ABPF2025-200 | | | 25 | 200 | 70 | | | | |
| OMV-ABPF2020-230 | | | 20 | 230 | 40 | | | | |
| OMV-ABPF2025-250 | | | 25 | 250 | 80 | | | | |
| OMV-ABPF2525-180 | 25 | 12.5 | 25 | 180 | 50 | ZPFG250 | 5025F | T30 | |
| OMV-ABPF2525-230 | | | 25 | 230 | 50 | | | | |
| OMV-ABPF2532-200 | | | 32 | 200 | 90 | | | | |
| OMV-ABPF2532-250 | | | 32 | 250 | 100 | | | | |
| OMV-ABPF2532-300 | 30 | 15 | 32 | 300 | 110 | ZPFG300 | 5030F | T30 | |
| OMV-ABPF3032-180 | | | 32 | 180 | 80 | | | | |
| OMV-ABPF3032-250 | | | 32 | 250 | 100 | | | | |
| OMV-ABPF3032-300 | | | 32 | 300 | 110 | | | | |
| OMV-ABPF3232-180 | 32 | 16 | 32 | 180 | 80 | ZPFG320 | 5030F | T30 | |
| OMV-ABPF3232-250 | | | 32 | 250 | 100 | | | | |
| OMV-ABPF3232-300 | | | 32 | 300 | 110 | | | | |
| OMV-ABPF3232-350 | | | 32 | 350 | 110 | | | | |
| OMV-ABPF3232-420 | | | 32 | 420 | 110 | | | | |

ABPF 球型精銑刀

ABPF BAL L PRECISION CUTTERS

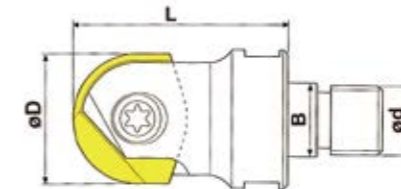

| 產品編號 Item Code | 尺寸 Dimensions (mm) | | | | 刀片型號 Insert | Screw | Wrench | 牌價 Price |
|-------------------|--------------------|----------|----|-----------|----------------|-------|--------|-------------|
| | D | d | L | B | | | | |
| OMVM-ABPF080 | 08 | M6x1.0 | 28 | M06 | ZPFG080 | 5008F | T8 | |
| OMVM-ABPF100 | 10 | M6x1.0 | 28 | M05 / M06 | ZPFG100 | 5010F | T10 | |
| OMVM-ABPF120 | 12 | M6x1.0 | 28 | M06 | ZPFG120 | 5012F | T20 | |
| OMVM-ABPF160 | 16 | M8x1.25 | 34 | M08 | ZPFG160 | 5016F | T20 | |
| OMVM-ABPF200 | 20 | M10x1.5 | 35 | M10 | ZPFG200 | 5020F | T25 | |
| OMVM-ABPF250 | 25 | M12x1.75 | 40 | M12 | ZPFG250 | 5025F | T30 | |
| OMVM-ABPF300 | 30 | M16x2.0 | 44 | M12 / M16 | ZPFG300 | 5030F | T30 | |

| 刀片型號 Description | M.C.T 磁浮刀片 | | |
|---------------------|------------|--------|---------|
| | WMX120 | VMH80D | VMH9303 |
| ZPFG080 | | | |
| ZPFG100 | | | |
| ZPFG120 | | | |
| ZP(D)FG160 | | | |
| ZP(D)FG200 | | | |
| ZP(D)FG250 | | | |
| ZP(D)FG300 | | | |

| 刀片型號 Description | 刀片形狀 Insert Shape | 尺寸 Dimensions (mm) | | | |
|---------------------|----------------------|--------------------|------|----|-----|
| | | R | A | ØB | T |
| ZPFG080 | | 4 | 9.7 | 8 | 2.1 |
| ZPFG100 | | 5 | 12.1 | 10 | 2.7 |
| ZPFG120 | | 6 | 14.6 | 12 | 3.2 |
| ZP(D)FG160 | | 8 | 16.6 | 16 | 4.2 |
| ZP(D)FG200 | | 10 | 20.3 | 20 | 5.2 |
| ZP(D)FG250 | | 12.5 | 24.1 | 25 | 6.2 |
| ZP(D)FG300 | | 15 | 29.2 | 30 | 7.2 |

(A) 銑刀
ENDMILLS
(B) 鑽頭
DRILLS
(C) 絞刀
REAMERS
(D) 絲攻
TAPS
(E) 刀桿/刀盤
MILLING CUTTERS
(F) 刀片
INSERTS

(A) 銑刀
ENDMILLS
(B) 鑽頭
DRILLS
(C) 絞刀
REAMERS
(D) 絲攻
TAPS
(E) 刀桿/刀盤
MILLING CUTTERS
(F) 刀片
INSERTS

高速、高效能銑刀

High-Speed And High-Efficiency End Mills



| 產品編號 Item Code | 刃徑 D | 刃長 Lc | 全長 L | 柄徑 d | 刃數 Teeth | 適用刀片 Insert | 牌價 Price |
|-------------------|---------|----------|---------|---------|-------------|---|-------------|
| ASM0708S10R-1 | 8 | 16 | 75 | 10 | SL1 |  JDMT0702 | |
| ASM0710S10R-2 | 10 | 20 | 120 | 10 | SL2 | | |
| ASM0710S08R-2 | 10 | 20 | 80 | 8 | SL2 | | |
| ASM0711S10R-2 | 11 | 20 | 80 | 10 | SL2 | | |
| ASM0712S12R-3 | 12 | 20 | 120 | 12 | SL3 | | |
| ASM0712S10R-3 | 12 | 20 | 80 | 10 | SL3 | | |
| ASM0714S12R-3 | 14 | 20 | 80 | 12 | SL3 | | |
| ASM0716S16R-4 | 16 | 25 | 90 | 16 | SL4 | | |
| ASML0716S16R-4 | 16 | 50 | 150 | 16 | SL4 | | |
| ASM0717S16R-4 | 17 | 20 | 150 | 16 | SL4 | | |
| ASM0720S20R-5 | 20 | 25 | 105 | 20 | SL5 | | |
| ASML0720S20R-5 | 20 | 60 | 150 | 20 | SL5 | | |
| ASM0721S20R-5 | 21 | 20 | 150 | 20 | SL5 | | |

高速、高效能銑刀

High-Speed And High-Efficiency End Mills

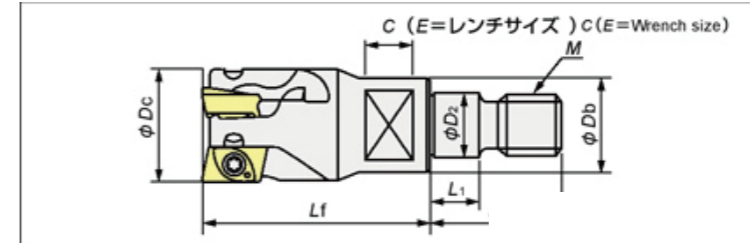

| 產品編號 Item Code | 刃徑 D | 刃長 Lc | 全長 L | 柄徑 d | 刃數 Teeth | 適用刀片 Insert | 牌價 Price |
|-------------------|---------|----------|---------|---------|-------------|---|-------------|
| ASMM0708R-1 | 8 | 20 | 34.5 | 9.8 | SL1 |  JDMT0702 | |
| ASMM0710R-2 | 10 | 20 | 34.5 | 9.4 | SL2 | | |
| ASMM0713R-3 | 11 | 20 | 34.5 | 9.8 | SL3 | | |
| ASMM0712R-3 | 12 | 20 | 34.5 | 9.8 | SL3 | | |
| ASMM0712R-2 | 12 | 20 | 34.5 | 9.8 | SL2 | | |
| ASMM0716R-4 | 16 | 20 | 37 | 12.8 | SL4 | | |
| ASMM0717R-3 | 17 | 25 | 42 | 12.8 | SL4 | | |
| ASMM0720R-5 | 20 | 25 | 44 | 17.8 | SL5 | | |
| ASMM07120R-4 | 20 | 30 | 49 | 17.8 | SL4 | | |
| ASMM0725R-6 | 20 | 30 | 52 | 20.8 | SL6 | | |
| ASMM0725R-5 | 20 | 30 | 52 | 20.8 | SL5 | | |
| ASMM0732R-8 | 20 | 30 | 53 | 28.8 | SL8 | | |
| ASMM0732R-5 | 20 | 30 | 53 | 28.8 | SL5 | | |

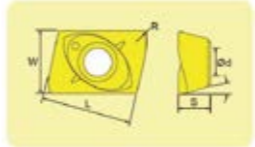
| 刀片型號 Description | 刀片形狀 Insert Shape | 尺寸 Dimensions (mm) | | | |
|---------------------|---|--------------------|-----|------|-----|
| | | L | W | S | r |
| JDMT070202 |  | 6.4 | 4.3 | 2.45 | 0.2 |
| JDMT070204 | | 6.4 | 4.3 | 2.45 | 0.4 |
| JDMT070208 | | 6.4 | 4.3 | 2.45 | 0.8 |

(A) 銑刀
ENDMILLS
(B) 鑽頭
DRILLS
(C) 絞刀
REAMERS
(D) 絲攻
TAPS
(E) 刀桿/刀盤
MILLING CUTTERS
(F) 刀片
INSERTS

(A) 銑刀
ENDMILLS
(B) 鑽頭
DRILLS
(C) 絞刀
REAMERS
(D) 絲攻
TAPS
(E) 刀桿/刀盤
MILLING CUTTERS
(F) 刀片
INSERTS

鑽銑刀

BORING & MILLING CUTTER

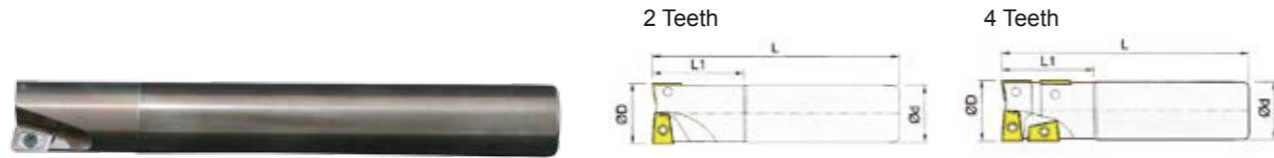

| 產品編號 Item Code | 尺寸 Dimensions (mm) | | | | 刃數 Teeth | 刀片型號 Insert | Screw | Wrench | 牌價 Price |
|--------------------|--------------------|----|-----|----|-------------|------------------|-------------|--------|-------------|
| | D | d | L | L1 | | | | | |
| OMV-AQXR1616-150 | 16 | 16 | 150 | 30 | 2 | QOM(G)T 0830R | MS 2205A | T07 | |
| OMV-AQXR1616-200 | 16 | 16 | 200 | 30 | 2 | | | | |
| OMV-AQXR1716-150 | 17 | 16 | 150 | 25 | 2 | | | | |
| OMV-AQXR1716-200 | 17 | 16 | 200 | 25 | 2 | QOM(G)T 1035R | MS 2506A | T09 | |
| OMV-AQXR2020-150 | 20 | 20 | 150 | 35 | 2 | | | | |
| OMV-AQXR2020-200 | 20 | 20 | 200 | 35 | 2 | | | | |
| OMV-AQXR2120-150 | 21 | 20 | 150 | 32 | 2 | QOM(G)T 1342R | MS 3008A | T09 | |
| OMV-AQXR2120-200 | 21 | 20 | 200 | 32 | 2 | | | | |
| OMV-AQXR2525-150 | 25 | 25 | 150 | 40 | 2 | | | | |
| OMV-AQXR2525-200 | 25 | 25 | 200 | 40 | 2 | QOM(G)T 1651R | MS 4009A | T15 | |
| OMV-AQXR2525-250 | 25 | 25 | 250 | 40 | 2 | | | | |
| OMV-AQXR2625-150 | 26 | 25 | 150 | 30 | 2 | | | | |
| OMV-AQXR2625-200 | 26 | 25 | 200 | 30 | 2 | QOM(G)T 1856R | MS 4011G | T15 | |
| OMV-AQXR2625-250 | 26 | 25 | 250 | 30 | 2 | | | | |
| OMV-AQXR3232-150 | 32 | 32 | 150 | 45 | 2 | | | | |
| OMV-AQXR3232-200 | 32 | 32 | 200 | 45 | 2 | QOM(G)T 2062R | MS 5011A | T20 | |
| OMV-AQXR3232-250 | 32 | 32 | 250 | 45 | 2 | | | | |
| OMV-AQXR3232-300 | 32 | 32 | 300 | 45 | 2 | | | | |
| OMV-AQXR3332-150 | 33 | 32 | 150 | 38 | 2 | | | | |
| OMV-AQXR3332-200 | 33 | 32 | 200 | 38 | 2 | | | | |
| OMV-AQXR3332-250 | 33 | 32 | 250 | 38 | 2 | | | | |
| OMV-AQXR3332-300 | 33 | 32 | 300 | 38 | 2 | | | | |
| OMV-AQXR3332*150-4 | 33 | 32 | 150 | 50 | 4 | | | | |
| OMV-AQXR3332*200-4 | 33 | 32 | 200 | 50 | 4 | | | | |
| OMV-AQXR3332*250-4 | 33 | 32 | 250 | 50 | 4 | | | | |
| OMV-AQXR3332*300-4 | 33 | 32 | 300 | 50 | 4 | | | | |
| OMV-AQXR3532-200 | 35 | 32 | 200 | 50 | 2 | | | | |
| OMV-AQXR4032-160 | 40 | 32 | 160 | 50 | 2 | | | | |

鑽銑刀

BORING & MILLING CUTTER



1. 同一刀片橫豎共用。
Using only one type of insert for 2 inserts bottom cutting edges.
2. 過中心平底切割。
Center cutting edge.

| 產品編號 Item Code | 尺寸 Dimensions (mm) | | | | 刃數 Teeth | 刀片型號 Insert | Screw | Wrench | 牌價 Price |
|-------------------|--------------------|------|----|-----|-------------|------------------|---------|--------|-------------|
| | D | d | L | M | | | | | |
| OMVM-AQXR162-M08 | 16 | 8.5 | 25 | M8 | 2 | QOM(G)T 0830R | MS2205A | T07 | |
| OMVM-AQXR172-M08 | 17 | 8.5 | 25 | M8 | 2 | QOM(G)T 1035R | MS2506A | T09 | |
| OMVM-AQXR202-M10 | 20 | 10.5 | 32 | M10 | 2 | | | | |
| OMVM-AQXR212-M10 | 21 | 10.5 | 32 | M10 | 2 | | | | |
| OMVM-AQXR252-M12 | 25 | 12.5 | 35 | M12 | 2 | QOM(G)T 1342R | MS3008A | T09 | |
| OMVM-AQXR262-M12 | 26 | 12.5 | 35 | M12 | 2 | QOM(G)T 1651R | MS4009A | T15 | |
| OMVM-AQXR322-M16 | 32 | 17 | 43 | M16 | 2 | | | | |
| OMVM-AQXR332-M16 | 33 | 17 | 43 | M16 | 2 | | | | |

| 刀片型號 Description | M.C.T 磁浮刀片 M.C.T Insert Coated | | |
|---------------------|--------------------------------|--------|--------|
| | WMM415 | VMM410 | WMM410 |
| QOM(G)T0830R | | | |
| QOM(G)T1035R | | | |
| QOM(G)T1342R | | | |
| QOM(G)T1651R | | | |
| QOM(G)T1856R | | | |
| QOM(G)T2062R | | | |

| 刀片型號 Description | 刀片形狀 Insert Shape | 尺寸 Dimensions (mm) | | | |
|---------------------|----------------------|--------------------|------|-----|-----|
| | | A | B | S | r |
| QOM(G)T0830R | | 8.4 | 5.5 | 3.0 | 0.8 |
| QOM(G)T1035R | | 10.6 | 7.0 | 3.5 | 0.8 |
| QOM(G)T1342R | | 13.1 | 8.7 | 4.2 | 0.8 |
| QOM(G)T1651R | | 16.5 | 11.0 | 5.1 | 0.8 |
| QOM(G)T1856R | | 18.0 | 12.0 | 5.6 | 0.8 |
| QOM(G)T2062R | | 20.4 | 13.6 | 6.2 | 0.8 |

(A) 銑刀
ENDMILLS
(B) 鑽頭
DRILLS
(C) 絞刀
REAMERS
(D) 絲攻
TAPS
(E) 刀桿/刀盤
MILLING CUTTERS
(F) 刀片
INSERTS

(A) 銑刀
ENDMILLS
(B) 鑽頭
DRILLS
(C) 絞刀
REAMERS
(D) 絲攻
TAPS
(E) 刀桿/刀盤
MILLING CUTTERS
(F) 刀片
INSERTS

鑽銑刀

THREAD- DRILLING end MILLING CUTTER

| 產品編號 1 - Item Code | 尺寸 Dimensions (mm) | | | | 刃數 Teeth | 刀片型號 Insert | | Screw | | Wrench | | 牌價 Price |
|-----------------------|--------------------|----|-----|----|-------------|-----------------|----------------|-------------|-------------|--------|-----|-------------|
| | D | d | L | L1 | | | | | | | | |
| OMV-AJU1616-150 | 16 | 16 | 150 | 30 | 2 | CPMT 080204Z | CCMT 060204 | MS 2506C | MS 2506C | T07 | --- | |
| OMV-AJU1616-200 | 16 | 16 | 200 | 30 | 2 | | | | | | | |
| OMV-AJU1716-150 | 17 | 16 | 150 | 25 | 2 | | | | | | | |
| OMV-AJU1716-200 | 17 | 16 | 200 | 25 | 2 | CPMT 090204Z | CCMT 060204 | MS 3507A | MS 2506C | T15 | T07 | |
| OMV-AJU2020-150 | 20 | 20 | 150 | 30 | 2 | | | | | | | |
| OMV-AJU2020-200 | 20 | 20 | 200 | 30 | 2 | | | | | | | |
| OMV-AJU2120-150 | 21 | 20 | 150 | 25 | 2 | CPMT 120308Z | CPMT 090308 | MS 4009A | MS 4009A | T15 | --- | |
| OMV-AJU2120-200 | 21 | 20 | 200 | 25 | 2 | | | | | | | |
| OMV-AJU2525-150 | 25 | 25 | 150 | 40 | 2 | | | | | | | |
| OMV-AJU2525-200 | 25 | 25 | 200 | 40 | 2 | CPMT 160408Z | CPMT 120408 | MS 5011A | MS 5011A | T20 | --- | |
| OMV-AJU2625-150 | 26 | 25 | 150 | 30 | 2 | | | | | | | |
| OMV-AJU2625-200 | 26 | 25 | 200 | 30 | 2 | | | | | | | |
| OMV-AJU3232-150 | 32 | 32 | 150 | 40 | 2 | CPMT 160408Z | CPMT 120408 | MS 5011A | MS 5011A | T20 | --- | |
| OMV-AJU3232-200 | 32 | 32 | 200 | 40 | 2 | | | | | | | |
| OMV-AJU3232-250 | 32 | 32 | 250 | 40 | 2 | | | | | | | |
| OMV-AJU3332-150 | 33 | 32 | 150 | 30 | 2 | CPMT 160408Z | CPMT 120408 | MS 5011A | MS 5011A | T20 | --- | |
| OMV-AJU3332-200 | 33 | 32 | 200 | 30 | 2 | | | | | | | |
| OMV-AJU3332-250 | 33 | 32 | 250 | 30 | 2 | | | | | | | |

| 刀片型號 Description | M.C.T磁浮刀片 M.C.T Insert Coated | | | |
|---------------------|-------------------------------|---------|---------------|---------------|
| | WMH9020 | VMH9020 | WMH9020 | VMH9020 |
| CCMT060204 | | | SKD61 | SKD61 |
| CPMT090308 | | | Vc : 200M/min | Vc : 350M/min |
| CPMT120408 | | | ap : 0.5m/min | ap : 0.5m/min |
| CPMT080204 | | | fz : 0.3mm/t | fz : 0.3mm/t |
| CPMT090204 | | | | |
| CPMT120308 | | | | |
| CPMT160408 | | | | |

鎖牙式鑽銑刀

THREAD- DRILLING end MILLING CUTTER



| 產品編號 2 - Item Code | 尺寸 Dimensions (mm) | | | | 刃數 Teeth | 刀片型號 Insert | | Screw | | Wrench | | 牌價 Price |
|-----------------------|--------------------|------|----|-----|-------------|-----------------|----------------|-------------|-------------|--------|-----|-------------|
| | D | d | L | M | | | | | | | | |
| OMVM-AJU16-M08 | 16 | 8.5 | 28 | M8 | 2 | CPMT 080204Z | CCMT 060204 | MS 2506A | MS 2506A | T07 | --- | |
| OMVM-AJU17-M08 | 17 | 8.5 | 28 | M8 | 2 | CPMT 090204Z | CCMT 060204 | MS 3507A | MS 2506C | T15 | T07 | |
| OMVM-AJU20-M10 | 20 | 10.5 | 32 | M10 | 2 | | | | | | | |
| OMVM-AJU21-M10 | 21 | 10.5 | 32 | M10 | 2 | | | | | | | |
| OMVM-AJU25-M12 | 25 | 12.5 | 38 | M12 | 2 | CPMT 120308Z | CPMT 090308 | MS 4009A | MS 4009A | T15 | --- | |
| OMVM-AJU26-M12 | 26 | 12.5 | 38 | M12 | 2 | CPMT 160408Z | CPMT 120408 | MS 5011A | MS 5011A | T20 | --- | |
| OMVM-AJU32-M16 | 32 | 17 | 43 | M16 | 2 | | | | | | | |
| OMVM-AJU33-M16 | 33 | 17 | 43 | M16 | 2 | | | | | | | |

| 刀片型號 Description | 刀片形狀 Insert Shape | 尺寸 Dimensions (mm) | | | | |
|---------------------|----------------------|--------------------|--------|-----|-----|----|
| | | S | A | Re | d1 | θ° |
| CCMT060204 | | 2.38 | 6.35 | 0.4 | 2.8 | 7 |
| CPMT090308 | | 3.18 | 9.525 | 0.8 | 4.4 | 11 |
| CPMT120408 | | 4.76 | 12.7 | 0.8 | 5.5 | 11 |
| CPMT080204 | | 2.38 | 7.94 | 0.4 | 2.8 | 11 |
| CPMT090204 | | 2.38 | 9.525 | 0.4 | 4.0 | 11 |
| CPMT120308 | | 3.18 | 12.7 | 0.8 | 4.5 | 11 |
| CPMT160408 | | 4.76 | 15.875 | 0.8 | 5.5 | 11 |

(A) 銑刀
ENDMILLS
(B) 鑽頭
DRILLS
(C) 絞刀
REAMERS
(D) 絲攻
TAPS
(E) 刀桿/刀盤
MILLING CUTTERS
(F) 刀片
INSERTS

(A) 銑刀
ENDMILLS
(B) 鑽頭
DRILLS
(C) 絞刀
REAMERS
(D) 絲攻
TAPS
(E) 刀桿/刀盤
MILLING CUTTERS
(F) 刀片
INSERTS

高進給半徑銑刀

SUPER RADIUS TD4N TYPE

替換式快速鑽頭

INDEXABLE INSERTS HIGH SPEED DRILLS

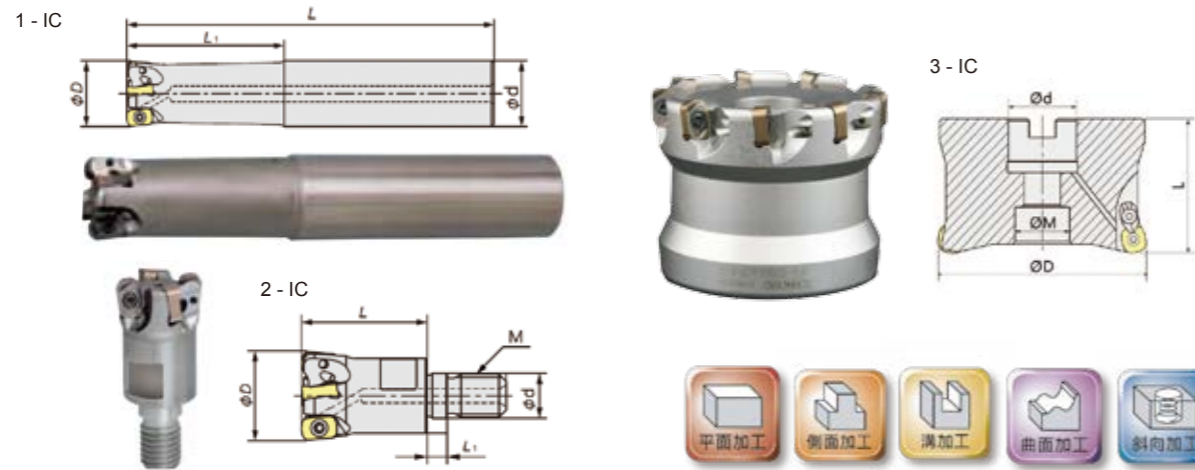

| 產品編號 1 - Item Code | 尺寸 Dimensions (mm) | | | | 刃數 Teeth | 刀片型號 Insert | Screw | Wrench | 牌價 Price |
|-----------------------|-----------------------|----|-----|----|-------------|----------------|---------|--------|-------------|
| | D | d | L | L1 | | | | | |
| OMV-TD4N1616*100-2 | 16 | 16 | 100 | 30 | 2 | ENMU0603 | 250-141 | T8 | |
| OMV-TD4N2020*130-3 | 20 | 20 | 130 | 50 | 3 | | | | |
| OMV-TD4N2525*140-4 | 25 | 25 | 140 | 60 | 4 | | | | |
| OMV-TD4N3532*200-5 | 35 | 32 | 200 | 40 | 5 | | | | |
| OMV-TD4N4032*220-6 | 40 | 32 | 220 | 45 | 6 | | | | |

| 產品編號 2 - Item Code | 尺寸 Dimensions (mm) | | | | | 刃數 Teeth | 刀片型號 Insert | Screw | Wrench | 牌價 Price |
|-----------------------|-----------------------|------|----|-----|-----|-------------|----------------|---------|--------|-------------|
| | D | d | L | L1 | M | | | | | |
| OMVM-TD4N16M8 | 17 | 8.5 | 25 | 5.5 | M8 | 2 | ENMU0603 | 250-141 | T8 | |
| OMVM-TD4N22M10 | 21 | 10.5 | 30 | 5.5 | M10 | 3 | | | | |
| OMVM-TD4N25M12 | 26 | 12.5 | 35 | 5.5 | M12 | 4 | | | | |
| OMVM-TD4N35M16 | 35 | 17 | 40 | 6 | M16 | 5 | | | | |
| OMVM-TD4N40M16 | 40 | 17 | 40 | 6 | M16 | 6 | | | | |

| 產品編號 3 - Item Code | 尺寸 Dimensions (mm) | | | | 刃數 Teeth | 刀片型號 Insert | Screw | Wrench | 牌價 Price |
|-----------------------|-----------------------|------|----|----|-------------|----------------|---------|--------|-------------|
| | D | d | L | M | | | | | |
| OFV-TD4N50*22-8 | 50 | 22 | 50 | 17 | 8 | ENMU0603 | 250-141 | T8 | |
| OFV-TD4N63*254-9 | 63 | 25.4 | 50 | 17 | 9 | | | | |
| OFV-TD4N80*254-11 | 80 | 25.4 | 70 | 20 | 11 | | | | |

| 刀片型號 Description | M.C.T 磁浮刀片 | | |
|---------------------|------------|---------|---------|
| | WMH9120 | WMH9160 | VMH9120 |
| ENMU0603 | | | |

| 刀片型號 Description | 刀片形狀 Insert Shape | 尺寸 Dimensions (mm) | | |
|---------------------|----------------------|-----------------------|---|-----|
| | | L | W | T |
| ENMU0603 | | 10 | 6 | 4.2 |



| 2D 產品編號 2D Item Code | L1 | 牌價 Price | 3D 產品編號 3D Item Code | L1 | 牌價 Price | 4D 產品編號 4D Item Code | L1 | 牌價 Price | 尺寸 Dimensions (mm) | | | | | 刀片 型號 Insert | |
|-------------------------|----|-------------|-------------------------|------|-------------|-------------------------|-----|-------------|-----------------------|----|----|----|----|--------------------|----------------|
| | | | | | | | | | D | d | d1 | L2 | L3 | | |
| ODV-C20D18027(1.5D) | 27 | | | | | | | | 18.0 | | | | | | WC.. 030208 |
| ODV-C20D185028(1.5D) | 28 | | | | | | | | 18.5 | | | | | | |
| ODV-C20D18036 | 36 | | ODV-C20D18054 | 54 | | | | | 18.0 | 20 | 29 | 52 | 24 | | |
| ODV-C20D19038 | 38 | | ODV-C20D19057 | 57 | | | | | 19.0 | | | | | | |
| ODV-C20D20040 | 40 | | ODV-C20D20060 | 60 | | | | | 20.0 | | | | | | |
| ODV-C25D18036 | 36 | | ODV-C25D18054 | 54 | | | | | 18.0 | | | | | WC.. 030208 | |
| ODV-C25D185037 | 37 | | ODV-C25D1850555 | 55.5 | | | | | 18.5 | | | | | | |
| ODV-C25D19038 | 38 | | ODV-C25D19057 | 57 | | | | | 19.0 | 25 | 35 | 56 | 24 | | |
| ODV-C25D20040 | 40 | | ODV-C25D20060 | 60 | | | | | 20.0 | | | | | | |
| | | | ODV-C25D2050615 | 61.5 | | | | | 20.5 | | | | | | |
| ODV-C25D21042 | 42 | | ODV-C25D21063 | 63 | | ODV-C25D21084 | 84 | | 21.0 | | | | | | WC.. 040208 |
| | | | ODV-C25D2150645 | 64.5 | | | | | 21.5 | | | | | | |
| ODV-C25D22044 | 44 | | ODV-C25D22066 | 66 | | ODV-C25D22088 | 88 | | 22.0 | | | | | | |
| | | | ODV-C25D2250675 | 67.5 | | | | | 22.5 | 25 | 35 | 56 | 24 | | |
| ODV-C25D23046 | 46 | | ODV-C25D23069 | 69 | | ODV-C25D23092 | 92 | | 23.0 | | | | | | |
| ODV-C25D24048 | 48 | | ODV-C25D24072 | 72 | | ODV-C25D24096 | 96 | | 24.0 | | | | | | |
| ODV-C25D25050 | 50 | | ODV-C25D25075 | 75 | | ODV-C25D25100 | 100 | | 25.0 | | | | | | |
| ODV-C32D26052 | 52 | | ODV-C32D26078 | 78 | | ODV-C32D26104 | 104 | | 26.0 | | | | | WC.. 050308 | |
| ODV-C32D27054 | 54 | | ODV-C32D27081 | 81 | | ODV-C32D27108 | 108 | | 27.0 | | | | | | |
| ODV-C32D28056 | 56 | | ODV-C32D28084 | 84 | | ODV-C32D28112 | 112 | | 28.0 | 32 | 43 | 60 | 29 | | |
| ODV-C32D29058 | 58 | | ODV-C32D29087 | 87 | | ODV-C32D29116 | 116 | | 29.0 | | | | | | |
| ODV-C32D30060 | 60 | | ODV-C32D30090 | 90 | | ODV-C32D30120 | 120 | | 30.0 | | | | | | |
| ODV-C32D31062 | 62 | | ODV-C32D31093 | 93 | | ODV-C32D31124 | 124 | | 31.0 | | | | | | |
| ODV-C32D32064 | 64 | | ODV-C32D32096 | 96 | | ODV-C32D32128 | 128 | | 32.0 | | | | | WC.. 06T308 | |
| ODV-C32D33066 | 66 | | ODV-C32D33099 | 99 | | ODV-C32D33132 | 132 | | 33.0 | 32 | 43 | 60 | 29 | | |
| ODV-C32D34068 | 68 | | ODV-C32D34102 | 102 | | ODV-C32D34136 | 136 | | 34.0 | | | | | | |
| ODV-C32D35070 | 70 | | ODV-C32D35105 | 105 | | ODV-C32D35140 | 140 | | 35.0 | | | | | | |
| ODV-C32D36072 | 72 | | ODV-C32D36108 | 108 | | ODV-C32D36144 | 144 | | 36.0 | | | | | | |
| ODV-C32D37074 | 74 | | ODV-C32D37111 | 111 | | ODV-C32D37148 | 148 | | 37.0 | | | | | | |
| ODV-C32D38076 | 76 | | ODV-C32D38114 | 114 | | ODV-C32D38152 | 152 | | 38.0 | 32 | 43 | 60 | 29 | WC.. 06T308 | |
| ODV-C32D39078 | 78 | | ODV-C32D39117 | 117 | | ODV-C32D39156 | 156 | | 39.0 | | | | | | |
| ODV-C32D40080 | 80 | | ODV-C32D40120 | 120 | | ODV-C32D40160 | 160 | | 40.0 | | | | | | |

| Description | Insert Shape | Dimensions (mm) | | | Screw | Wrench |
|-------------|--------------|-----------------|------|-----|---------|--------|
| | | lc | S | Re | | |
| WCMX030208 | | 5.65 | 2.38 | 0.8 | MS2506E | T08 |
| WCMX040208 | | 6.35 | 2.38 | 0.8 | MS2506E | T08 |
| WCMT050308 | | 7.94 | 3.18 | 0.8 | MS3008B | T09 |
| WCMT06T308 | | 9.525 | 3.97 | 0.8 | MS3510E | T10 |

(A) 銑刀
ENDMILLS
(B) 鑽頭
DRILLS
(C) 絞刀
REAMERS
(D) 絲攻
TAPS
(E) 刀桿/刀盤
MILLING CUTTERS
(F) 刀片
INSERTS

(A) 銑刀
ENDMILLS
(B) 鑽頭
DRILLS
(C) 絞刀
REAMERS
(D) 絲攻
TAPS
(E) 刀桿/刀盤
MILLING CUTTERS
(F) 刀片
INSERTS

磁浮替刃鑽頭 / 2 倍長

M.C.T. Replaceable Insert Drill
2D



使用M.C.T.刀片可高速連續加工，不產生高溫，提高產能。
Using M.C.T. can process in high speed continuously and resist the high temperature during metal process to highten productivity.

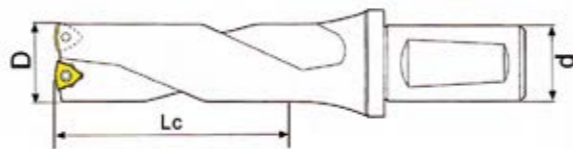

| 產品編號 Item Code | 刃徑 D | 刃長 Lc | d | 刀片型號 Insert | 刀片螺絲 Screw | 扳手 Wrench | 牌價 Price |
|-------------------|---------|----------|----|----------------|-------------------|--------------|----------------|
| WODV-C25D15030 | 15 | 30 | 25 | WCMX 030208 | M2.5 (S2502-1) | T8 | |
| WODV-C25D16032 | 16 | 32 | 25 | | | | |
| WODV-C25D165032 | 16.5 | 32 | 25 | | | | |
| WODV-C25D17034 | 17 | 34 | 25 | | | | |
| WODV-C25D175034 | 17.5 | 34 | 25 | | | | |
| WODV-C25D18036 | 18 | 36 | 25 | | | | |
| WODV-C25D185036 | 18.5 | 36 | 25 | | | | |
| WODV-C25D19038 | 19 | 38 | 25 | | | | |
| WODV-C25D195038 | 19.5 | 38 | 25 | | | | |
| WODV-C25D20040 | 20 | 40 | 25 | | | | |
| WODV-C25D205040 | 20.5 | 40 | 25 | WCMX 040208 | M2.5 (S2502-1) | T8 | |
| WODV-C25D21042 | 21 | 42 | 25 | | | | |
| WODV-C25D215042 | 21.5 | 42 | 25 | | | | |
| WODV-C25D22044 | 22 | 44 | 25 | | | | |
| WODV-C25D225044 | 22.5 | 44 | 25 | | | | |
| WODV-C25D23046 | 23 | 46 | 25 | | | | |
| WODV-C25D235046 | 23.5 | 46 | 25 | | | | |
| WODV-C25D24048 | 24 | 48 | 25 | | | | |
| WODV-C25D245048 | 24.5 | 48 | 25 | | | | |
| WODV-C32D25050 | 25 | 50 | 32 | | | | WCMX 050308 |
| WODV-C32D255050 | 25.5 | 50 | 32 | | | | |
| WODV-C32D26052 | 26 | 52 | 32 | | | | |
| WODV-C32D265052 | 26.5 | 52 | 32 | | | | |
| WODV-C32D27054 | 27 | 54 | 32 | | | | |
| WODV-C32D275054 | 27.5 | 54 | 32 | | | | |
| WODV-C32D28056 | 28 | 56 | 32 | | | | |

磁浮替刃鑽頭 / 2 倍長

M.C.T. Replaceable Insert Drill
2D

| 產品編號 Item Code | 刃徑 D | 刃長 Lc | 柄徑 d | 刀片型號 Insert | 刀片螺絲 Screw | 扳手 Wrench | 牌價 Price |
|-------------------|---------|----------|---------|----------------|-------------------|--------------|-------------|
| WODV-C32D285056 | 28.5 | 56 | 32 | WCMX 050308 | M3.0 (S3002-1) | T8 | |
| WODV-C32D29058 | 29 | 58 | 32 | | | | |
| WODV-C32D295058 | 29.5 | 58 | 32 | | | | |
| WODV-C32D30060 | 30 | 60 | 32 | WCMX 06T308 | M3.5 (S3506-1) | T15 | |
| WODV-C32D31062 | 31 | 62 | 32 | | | | |
| WODV-C32D32064 | 32 | 64 | 32 | | | | |
| WODV-C32D33066 | 33 | 66 | 32 | | | | |
| WODV-C32D34068 | 34 | 68 | 32 | | | | |
| WODV-C32D35070 | 35 | 70 | 32 | | | | |
| WODV-C32D36072 | 36 | 72 | 32 | | | | |
| WODV-C32D37074 | 37 | 74 | 32 | | | | |
| WODV-C32D38076 | 38 | 76 | 32 | WCMX 080412 | M4.0 (S4005) | T15 | |
| WODV-C32D39078 | 39 | 78 | 32 | | | | |
| WODV-C40D40080 | 40 | 80 | 40 | | | | |
| WODV-C40D41082 | 41 | 82 | 40 | | | | |
| WODV-C40D42084 | 42 | 84 | 40 | | | | |
| WODV-C40D43086 | 43 | 86 | 40 | | | | |
| WODV-C40D44088 | 44 | 88 | 40 | | | | |
| WODV-C40D45090 | 45 | 90 | 40 | | | | |
| WODV-C40D46092 | 46 | 92 | 40 | | | | |
| WODV-C40D47094 | 47 | 94 | 40 | | | | |
| WODV-C40D48096 | 48 | 96 | 40 | | | | |
| WODV-C40D49098 | 49 | 98 | 40 | | | | |
| WODV-C40D50100 | 50 | 100 | 40 | | | | |

| 刀片型號 Description | M.C.T磁浮刀片 M.C.T Insert Coated | | | | 刀片形狀 Insert Shape | 尺寸 Dimensions (mm) | | |
|---------------------|----------------------------------|-------------|-------------|------------|----------------------|-----------------------|------|-----|
| | VMU 4010 | WMM 4720 | VMM 4720 | WMM 415 | | A | T | r |
| WCMX030208 | | | | | | 5.56 | 2.38 | 0.8 |
| WCMX040208 | | | | | | 6.35 | 2.38 | 0.8 |
| WCMX050308 | | | | | | 7.94 | 3.18 | 0.8 |
| WCMX06T308 | | | | | | 9.525 | 3.97 | 0.8 |
| WCMX080412 | | | | | | 12.7 | 4.76 | 1.2 |

(A) 銑刀
ENDMILLS

(B) 鑽頭
DRILLS

(C) 絞刀
REAMERS

(D) 絲攻
TAPS

(E) 刀桿/刀盤
MILLING CUTTERS

(F) 刀片
INSERTS

(A) 銑刀
ENDMILLS

(B) 鑽頭
DRILLS

(C) 絞刀
REAMERS

(D) 絲攻
TAPS

(E) 刀桿/刀盤
MILLING CUTTERS

(F) 刀片
INSERTS

磁浮替刃鑽頭 /3 倍長

M.C.T. Replaceable Insert Drill
3D

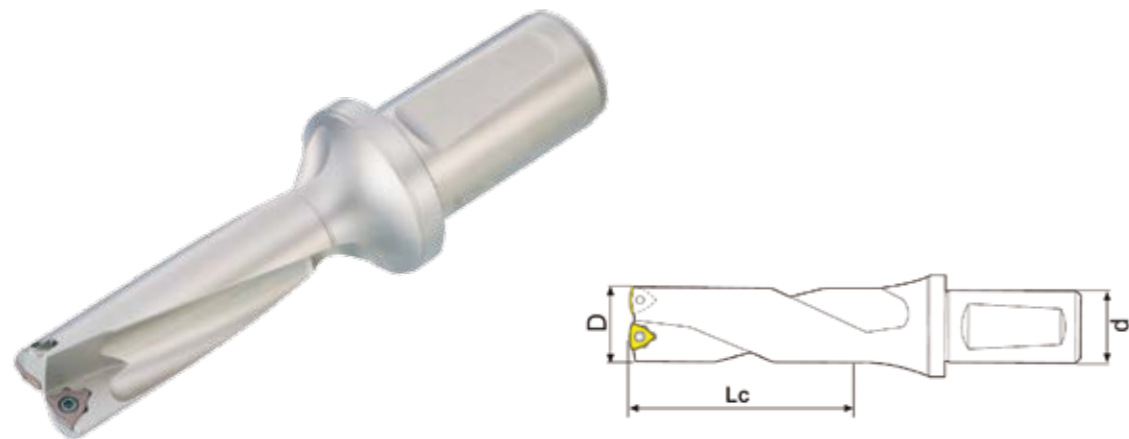

| 產品編號 Item Code | 刃徑 D | 刃長 Lc | 柄徑 d | 刀片型號 Insert | 刀片螺絲 Screw | 扳手 Wrench | 牌價 Price |
|-------------------|---------|----------|---------|----------------|-------------------|--------------|-------------|
| WODV-C25D14042 | 14 | 42 | 25 | WCMX 030208 | M2.5 (S2502-1) | T8 | |
| WODV-C25D15045 | 15 | 45 | 25 | | | | |
| WODV-C25D16048 | 16 | 48 | 25 | | | | |
| WODV-C25D165048 | 16.5 | 48 | 25 | | | | |
| WODV-C25D17051 | 17 | 51 | 25 | | | | |
| WODV-C25D175051 | 17.5 | 51 | 25 | | | | |
| WODV-C25D18054 | 18 | 54 | 25 | | | | |
| WODV-C25D185054 | 18.5 | 54 | 25 | | | | |
| WODV-C25D19057 | 19 | 57 | 25 | | | | |
| WODV-C25D195057 | 19.5 | 57 | 25 | | | | |
| WODV-C25D20060 | 20 | 60 | 25 | WCMX 040208 | M2.5 (S2502-1) | T8 | |
| WODV-C25D21063 | 21 | 63 | 25 | | | | |
| WODV-C25D22066 | 22 | 66 | 25 | | | | |
| WODV-C25D23069 | 23 | 69 | 25 | | | | |
| WODV-C25D24072 | 24 | 72 | 25 | | | | |
| WODV-C32D20060 | 20 | 60 | 32 | | | | |
| WODV-C32D205060 | 20.5 | 60 | 32 | | | | |
| WODV-C32D21063 | 21 | 63 | 32 | | | | |
| WODV-C32D215063 | 21.5 | 63 | 32 | | | | |
| WODV-C32D22066 | 22 | 66 | 32 | | | | |
| WODV-C32D225066 | 22.5 | 66 | 32 | | | | |
| WODV-C32D23069 | 23 | 69 | 32 | | | | |

磁浮替刃鑽頭 /3 倍長

M.C.T. Replaceable Insert Drill
3D

| 產品編號 Item Code | 刃徑 D | 刃長 Lc | 柄徑 d | 刀片型號 Insert | 刀片螺絲 Screw | 扳手 Wrench | 牌價 Price |
|-------------------|---------|----------|---------|----------------|-------------------|--------------|-------------|
| WODV-C32D235069 | 23.5 | 69 | 32 | WCMX 040208 | M2.5 (S2502-1) | T8 | |
| WODV-C32D24072 | 24 | 72 | 32 | | | | |
| WODV-C32D245072 | 24.5 | 72 | 32 | | | | |
| WODV-C32D25075 | 25 | 75 | 32 | WCMX 050308 | M3.0 (S3002-1) | T8 | |
| WODV-C32D255075 | 25.5 | 75 | 32 | | | | |
| WODV-C32D26078 | 26 | 78 | 32 | | | | |
| WODV-C32D265078 | 26.5 | 78 | 32 | | | | |
| WODV-C32D27081 | 27 | 81 | 32 | | | | |
| WODV-C32D275081 | 27.5 | 81 | 32 | | | | |
| WODV-C32D28084 | 28 | 84 | 32 | | | | |
| WODV-C32D285084 | 28.5 | 84 | 32 | | | | |
| WODV-C32D29087 | 29 | 87 | 32 | | | | |
| WODV-C32D295087 | 29.5 | 87 | 32 | | | | |
| WODV-C32D30090 | 30 | 90 | 32 | WCMX 06T308 | M3.5 (S3506-1) | T15 | |
| WODV-C32D31093 | 31 | 93 | 32 | | | | |
| WODV-C32D32096 | 32 | 96 | 32 | | | | |
| WODV-C32D33099 | 33 | 99 | 32 | | | | |
| WODV-C32D34102 | 34 | 102 | 32 | | | | |
| WODV-C32D35105 | 35 | 105 | 32 | | | | |
| WODV-C32D36108 | 36 | 108 | 32 | | | | |
| WODV-C32D37111 | 37 | 111 | 32 | | | | |
| WODV-C32D38114 | 38 | 114 | 32 | | | | |
| WODV-C32D39117 | 39 | 117 | 32 | | | | |
| WODV-C40D40120 | 40 | 120 | 40 | WCMX 080412 | M4.0 (S4005) | T15 | |
| WODV-C40D41123 | 41 | 123 | 40 | | | | |
| WODV-C40D42126 | 42 | 126 | 40 | | | | |
| WODV-C40D43129 | 43 | 129 | 40 | | | | |
| WODV-C40D44132 | 44 | 132 | 40 | | | | |
| WODV-C40D45135 | 45 | 135 | 40 | | | | |
| WODV-C40D46138 | 46 | 138 | 40 | | | | |
| WODV-C40D47141 | 47 | 141 | 40 | | | | |
| WODV-C40D48144 | 48 | 144 | 40 | | | | |
| WODV-C40D49147 | 49 | 147 | 40 | | | | |

(A) 銑刀
ENDMILLS
(B) 鑽頭
DRILLS
(C) 絞刀
REAMERS
(D) 絲攻
TAPS
(E) 刀桿/刀盤
MILLING CUTTERS
(F) 刀片
INSERTS

(A) 銑刀
ENDMILLS
(B) 鑽頭
DRILLS
(C) 絞刀
REAMERS
(D) 絲攻
TAPS
(E) 刀桿/刀盤
MILLING CUTTERS
(F) 刀片
INSERTS

磁浮替刃鑽頭 /3 倍長

M.C.T. Replaceable Insert Drill
3D

(A) 銑刀
ENDMILLS

(B) 鑽頭
DRILLS

(C) 絞刀
REAMERS

(D) 絲攻
TAPS

(E) 刀桿/刀盤
MILLING CUTTERS

(F) 刀片
INSERTS

| 產品編號 Item Code | 刃徑 D | 刃長 Lc | 柄徑 d | 刀片型號 Insert | 刀片螺絲 Screw | 扳手 Wrench | 牌價 Price |
|-------------------|---------|----------|---------|------------------|-------------------|--------------|-------------|
| WODV-C40D50150 | 50 | 150 | 40 | WCMX 080412 | M4.0 (S4005) | T15 | |
| WODV-C40D51153 | 51 | 153 | 40 | | | | |
| WODV-C40D52156 | 52 | 156 | 40 | | | | |
| WODV-C40D53159 | 53 | 159 | 40 | | | | |
| WODV-C40D54162 | 54 | 162 | 40 | | | | |
| WODV-C40D55165 | 55 | 165 | 40 | | | | |
| WODV-C40D56168 | 56 | 168 | 40 | | | | |
| WODV-C40D57171 | 57 | 171 | 40 | | | | |
| WODV-C40D58174 | 58 | 174 | 40 | | | | |
| WODV-C40D59177 | 59 | 177 | 40 | | | | |
| WODV-C40D60180 | 60 | 180 | 40 | ▲ WCMX 06T308 | M3.5 (S3506-1) | T15 | |
| WODV-C40D61183 | 61 | 183 | 40 | | | | |
| WODV-C40D62186 | 62 | 186 | 40 | | | | |
| WODV-C40D63189 | 63 | 189 | 40 | | | | |
| WODV-C40D64192 | 64 | 192 | 40 | | | | |
| WODV-C40D65195 | 65 | 195 | 40 | | | | |
| WODV-C40D66198 | 66 | 198 | 40 | | | | |
| WODV-C40D67201 | 67 | 201 | 40 | | | | |
| WODV-C40D68204 | 68 | 204 | 40 | | | | |
| WODV-C40D69207 | 69 | 207 | 40 | | | | |
| WODV-C40D70210 | 70 | 210 | 40 | ▲ WCMX 090508 | M5.0 (S5003-2) | T20 | |

| 刀片型號 Description | M.C.T 磁浮刀片 M.C.T Insert Coated | | | | 刀片形狀 Insert Shape | 尺寸 Dimensions (mm) | | |
|---------------------|-----------------------------------|-------------|-------------|------------|----------------------|-----------------------|------|-----|
| | VMM 4010 | WMM 4720 | VMM 4720 | WMM 415 | | A | T | r |
| WCMX030208 | | | | | | 5.56 | 2.38 | 0.8 |
| WCMX040208 | | | | | | 6.35 | 2.38 | 0.8 |
| WCMX050308 | | | | | | 7.94 | 3.18 | 0.8 |
| ▲ WCMX06T308 | | | | | | 9.525 | 3.97 | 0.8 |
| WCMX080412 | | | | | | 12.7 | 4.76 | 1.2 |
| ▲ WCMX090508 | | | | | | 16.0 | 5.56 | 0.8 |

▲ 當 WC09 鑽頭銷售完庫存，將供應 WC06 系列鑽頭
When the WC09 drill bit is sold out, the WC06 series drill bit will be supplied.

磁浮替刃鑽頭 4 倍長

M.C.T. Replaceable Insert Drill
4D

(A) 銑刀
ENDMILLS

(B) 鑽頭
DRILLS

(C) 絞刀
REAMERS

(D) 絲攻
TAPS

(E) 刀桿/刀盤
MILLING CUTTERS

(F) 刀片
INSERTS



| 產品編號 Item Code | 刃徑 D | 刃長 Lc | 柄徑 d | 刀片型號 Insert | 刀片螺絲 Screw | 扳手 Wrench | 牌價 Price |
|-------------------|---------|----------|---------|----------------|-------------------|--------------|----------------|
| WODV-C25D15060 | 15 | 60 | 25 | WCMX 030208 | M2.5 (S2502-1) | T8 | |
| WODV-C25D16064 | 16 | 64 | 25 | | | | |
| WODV-C25D165064 | 16.5 | 64 | 25 | | | | |
| WODV-C25D17068 | 17 | 68 | 25 | | | | |
| WODV-C25D175068 | 17.5 | 68 | 25 | | | | |
| WODV-C25D18072 | 18 | 72 | 25 | | | | |
| WODV-C25D185072 | 18.5 | 72 | 25 | | | | |
| WODV-C25D19076 | 19 | 76 | 25 | | | | |
| WODV-C25D195076 | 19.5 | 76 | 25 | | | | |
| WODV-C32D20080 | 20 | 80 | 32 | | | | WCMX 040208 |
| WODV-C32D205080 | 20.5 | 80 | 32 | | | | |
| WODV-C32D21084 | 21 | 84 | 32 | | | | |
| WODV-C32D215084 | 21.5 | 84 | 32 | | | | |
| WODV-C32D22088 | 22 | 88 | 32 | | | | |
| WODV-C32D225088 | 22.5 | 88 | 32 | | | | |
| WODV-C32D23092 | 23 | 92 | 32 | | | | |

磁浮替刃鑽頭 /4 倍長

M.C.T. Replaceable Insert Drill
4D

(A) 銑刀
ENDMILLS
(B) 鑽頭
DRILLS
(C) 絞刀
REAMERS
(D) 絲攻
TAPS
(E) 刀桿/刀盤
MILLING CUTTERS
(F) 刀片
INSERTS

| 產品編號 Item Code | 刃徑 D | 刃長 Lc | 柄徑 d | 刀片型號 Insert | 刀片螺絲 Screw | 扳手 Wrench | 牌價 Price |
|-------------------|---------|----------|---------|----------------|-------------------|--------------|-------------|
| WODV-C32D235092 | 23.5 | 92 | 32 | WCMX 040208 | M2.5 (S2502-1) | T8 | |
| WODV-C32D24096 | 24 | 96 | 32 | | | | |
| WODV-C32D245096 | 24.5 | 96 | 32 | | | | |
| WODV-C32D25100 | 25 | 100 | 32 | WCMX 050308 | M3.0 (S3002-1) | T8 | |
| WODV-C32D255100 | 25.5 | 100 | 32 | | | | |
| WODV-C32D26104 | 26 | 104 | 32 | | | | |
| WODV-C32D265104 | 26.5 | 104 | 32 | | | | |
| WODV-C32D27108 | 27 | 108 | 32 | | | | |
| WODV-C32D275108 | 27.5 | 108 | 32 | | | | |
| WODV-C32D28112 | 28 | 112 | 32 | | | | |
| WODV-C32D285112 | 28.5 | 112 | 32 | WCMX 06T308 | M3.5 (S3506-1) | T15 | |
| WODV-C32D29116 | 29 | 116 | 32 | | | | |
| WODV-C32D295116 | 29.5 | 116 | 32 | | | | |
| WODV-C32D30120 | 30 | 120 | 32 | | | | |
| WODV-C32D31124 | 31 | 124 | 32 | | | | |
| WODV-C32D32128 | 32 | 128 | 32 | | | | |
| WODV-C32D33132 | 33 | 132 | 32 | | | | |
| WODV-C32D34136 | 34 | 136 | 32 | | | | |
| WODV-C32D35140 | 35 | 140 | 32 | | | | |
| WODV-C32D36144 | 36 | 144 | 32 | | | | |
| WODV-C32D37148 | 37 | 148 | 32 | | | | |
| WODV-C32D38152 | 38 | 152 | 32 | | | | |
| WODV-C32D39156 | 39 | 156 | 32 | | | | |

磁浮替刃鑽頭 4 倍長

M.C.T. Replaceable Insert Drill
4D

(A) 銑刀
ENDMILLS
(B) 鑽頭
DRILLS
(C) 絞刀
REAMERS
(D) 絲攻
TAPS
(E) 刀桿/刀盤
MILLING CUTTERS
(F) 刀片
INSERTS

| 產品編號 Item Code | 刃徑 D | 刃長 Lc | 柄徑 d | 刀片型號 Insert | 刀片螺絲 Screw | 扳手 Wrench | 牌價 Price |
|-------------------|---------|----------|---------|----------------|-----------------|--------------|-------------|
| WODV-C40D40160 | 40 | 160 | 40 | WCMX 080412 | M4.0 (S4005) | T15 | |
| WODV-C40D41164 | 41 | 164 | 40 | | | | |
| WODV-C40D42168 | 42 | 168 | 40 | | | | |
| WODV-C40D43172 | 43 | 172 | 40 | | | | |
| WODV-C40D44176 | 44 | 176 | 40 | | | | |
| WODV-C40D45180 | 45 | 180 | 40 | | | | |
| WODV-C40D46184 | 46 | 184 | 40 | | | | |
| WODV-C40D47188 | 47 | 188 | 40 | | | | |
| WODV-C40D48192 | 48 | 192 | 40 | | | | |
| WODV-C40D49196 | 49 | 196 | 40 | | | | |
| WODV-C40D50200 | 50 | 200 | 40 | | | | |
| WODV-C40D51204 | 51 | 204 | 40 | | | | |
| WODV-C40D52208 | 52 | 208 | 40 | | | | |
| WODV-C40D53212 | 53 | 212 | 40 | | | | |
| WODV-C40D54216 | 54 | 216 | 40 | | | | |
| WODV-C40D55220 | 55 | 220 | 40 | | | | |
| WODV-C40D56224 | 56 | 224 | 40 | | | | |
| WODV-C40D57228 | 57 | 228 | 40 | | | | |
| WODV-C40D58232 | 58 | 232 | 40 | | | | |
| WODV-C40D59236 | 59 | 236 | 40 | | | | |
| WODV-C40D60240 | 60 | 240 | 40 | | | | |

| 刀片型號 Description | M.C.T 磁浮刀片 M.C.T Insert Coated | | | | 刀片形狀 Insert Shape | 尺寸 Dimensions (mm) | | |
|---------------------|-----------------------------------|-------------|-------------|------------|----------------------|-----------------------|------|-----|
| | VMM 4010 | WMM 4720 | VMM 4720 | WMM 415 | | A | T | r |
| WCMX030208 | | | | | | 5.56 | 2.38 | 0.8 |
| WCMX040208 | | | | | | 6.35 | 2.38 | 0.8 |
| WCMX050308 | | | | | | 7.94 | 3.18 | 0.8 |
| WCMX06T308 | | | | | | 9.525 | 3.97 | 0.8 |
| WCMX080412 | | | | | | 12.7 | 4.76 | 1.2 |

磁浮替刃鑽頭 /5 倍長

M.C.T. Replaceable Insert Drill
5D

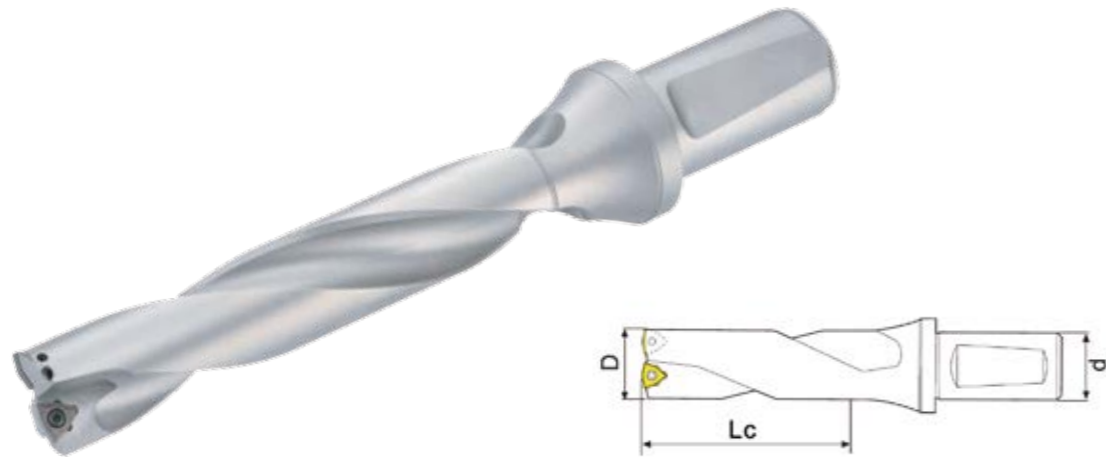

| 產品編號 Item Code | 刃徑 D | 刃長 Lc | 柄徑 d | 刀片型號 Insert | 刀片螺絲 Screw | 扳手 Wrench | 牌價 Price |
|-------------------|---------|----------|---------|----------------|-------------------|--------------|-------------|
| WODV-C32D20100 | 20 | 100 | 32 | WCMX 040208 | M2.5 (S2502-1) | T8 | |
| WODV-C32D21105 | 21 | 105 | 32 | | | | |
| WODV-C32D22110 | 22 | 110 | 32 | | | | |
| WODV-C32D23115 | 23 | 115 | 32 | | | | |
| WODV-C32D24120 | 24 | 120 | 32 | | | | |
| WODV-C32D25125 | 25 | 125 | 32 | WCMX 050308 | M3.0 (S3002-1) | T8 | |
| WODV-C32D26130 | 26 | 130 | 32 | | | | |
| WODV-C32D27135 | 27 | 135 | 32 | | | | |
| WODV-C32D28140 | 28 | 140 | 32 | | | | |
| WODV-C32D29145 | 29 | 145 | 32 | | | | |
| WODV-C32D30150 | 30 | 150 | 32 | WCMX 06T308 | M3.5 (S3506-1) | T15 | |
| WODV-C32D31155 | 31 | 155 | 32 | | | | |
| WODV-C32D32160 | 32 | 160 | 32 | | | | |
| WODV-C32D33165 | 33 | 165 | 32 | | | | |
| WODV-C32D34170 | 34 | 170 | 32 | | | | |
| WODV-C32D35175 | 35 | 175 | 32 | | | | |
| WODV-C32D36180 | 36 | 180 | 32 | | | | |
| WODV-C32D37185 | 37 | 185 | 32 | | | | |

磁浮替刃鑽頭 /5 倍長

M.C.T. Replaceable Insert Drill
5D

| 產品編號 Item Code | 刃徑 D | 刃長 Lc | 柄徑 d | 刀片型號 Insert | 刀片螺絲 Screw | 扳手 Wrench | 牌價 Price |
|-------------------|---------|----------|---------|----------------|-------------------|--------------|-------------|
| WODV-C32D38190 | 38 | 190 | 32 | WCMX 06T308 | M3.5 (S3506-1) | T15 | |
| WODV-C32D39195 | 39 | 195 | 32 | | | | |
| WODV-C40D40200 | 40 | 200 | 40 | WCMX 080412 | M4.0 (S4005) | T15 | |
| WODV-C40D41205 | 41 | 205 | 40 | | | | |
| WODV-C40D42210 | 42 | 210 | 40 | | | | |
| WODV-C40D43215 | 43 | 215 | 40 | | | | |
| WODV-C40D44220 | 44 | 220 | 40 | | | | |
| WODV-C40D45225 | 45 | 225 | 40 | | | | |
| WODV-C40D46230 | 46 | 230 | 40 | | | | |
| WODV-C40D47235 | 47 | 235 | 40 | | | | |
| WODV-C40D48240 | 48 | 240 | 40 | | | | |
| WODV-C40D49245 | 49 | 245 | 40 | | | | |
| WODV-C40D50250 | 50 | 250 | 40 | | | | |
| WODV-C40D51255 | 51 | 255 | 40 | | | | |
| WODV-C40D52260 | 52 | 260 | 40 | | | | |
| WODV-C40D53265 | 53 | 265 | 40 | | | | |
| WODV-C40D54270 | 54 | 270 | 40 | | | | |
| WODV-C40D55275 | 55 | 275 | 40 | | | | |

| 刀片型號 Description | M.C.T 磁浮刀片 M.C.T Insert Coated | | | | 刀片形狀 Insert Shape | 尺寸 Dimensions (mm) | | |
|---------------------|-----------------------------------|-------------|-------------|------------|----------------------|-----------------------|------|-----|
| | VMM 4010 | WMM 4720 | VMM 4720 | WMU 310 | | A | T | r |
| WCMX040208 | | | | | | 6.35 | 2.38 | 0.8 |
| WCMX050308 | | | | | | 7.94 | 3.18 | 0.8 |
| WCMX06T308 | | | | | | 9.525 | 3.97 | 0.8 |
| WCMX080412 | | | | | | 12.7 | 4.76 | 1.2 |

(A) 銑刀
ENDMILLS
(B) 鑽頭
DRILLS
(C) 絞刀
REAMERS
(D) 絲攻
TAPS
(E) 刀桿/刀盤
MILLING CUTTERS
(F) 刀片
INSERTS

(A) 銑刀
ENDMILLS
(B) 鑽頭
DRILLS
(C) 絞刀
REAMERS
(D) 絲攻
TAPS
(E) 刀桿/刀盤
MILLING CUTTERS
(F) 刀片
INSERTS

SPMG快速鑽頭(3倍)

3X Diameter Drill Depth

捨棄式快速鑽頭，有效鑽深為直徑的三倍長
Throw-away high speed drill, the drill depth is three times to the diameter.

標準庫存直徑範圍: $\phi 12.5 \sim \phi 65$

公差(mm): $0 \sim \pm 0.2$ ，可依需求配合生產。
Hole tolerance(mm): $0 \sim \pm 0.2$

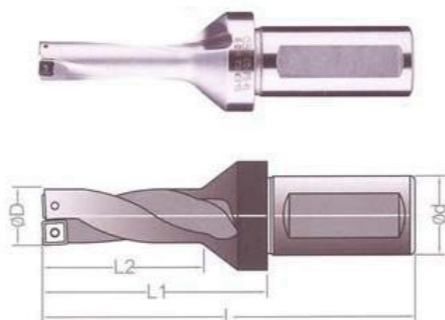

適合加工孔



| 產品編號 Item Code | 尺寸 Dimensions (mm) | | | | 側固 柄徑 d | 刀片型號 Insert | Screw | Wrench | 牌價 Price | | |
|-------------------|--------------------|------|-----|------|-------------|----------------|--------|--------|-------------|-----|------|
| | D | L | L1 | L2 | | | | | | | |
| OMV-SP12.5-3D | 12.5 | 123 | 67 | 37.5 | 25 | SPMG 050204 | M2.0*5 | T6 | | | |
| OMV-SP13-3D | 13 | 126 | 70 | 39 | | | | | | | |
| OMV-SP13.5-3D | 13.5 | | | 40.5 | | | | | | | |
| OMV-SP14-3D | 14 | 129 | 73 | 42 | | | | | | | |
| OMV-SP14.5-3D | 14.5 | | | 43.5 | | | | | | | |
| OMV-SP15-3D | 15 | 132 | 76 | 45 | | | | | | | |
| OMV-SP15.5-3D | 15.5 | | | 46.5 | | | | | | | |
| OMV-SP16-3D | 16 | 135 | 79 | 48 | | | | | | | |
| OMV-SP16.5-3D | 16.5 | | | 49.5 | | | | | | | |
| OMV-SP17-3D | 17 | 138 | 82 | 51 | | | | | | | |
| OMV-SP17.5-3D | 17.5 | | | 52.5 | | | | | | | |
| OMV-SP18-3D | 18 | 141 | 85 | 54 | | | | | | | |
| OMV-SP18.5-3D | 18.5 | | | 55.5 | | | | | | | |
| OMV-SP19-3D | 19 | 144 | 88 | 57 | | | | | | | |
| OMV-SP19.5-3D | 19.5 | | | 58.5 | | | | | | | |
| OMV-SP20-3D | 20 | 147 | 91 | 60 | | | | | | | |
| OMV-SP20.5-3D | 20.5 | | | 61.5 | | | | | | | |
| OMV-SP21-3D | 21 | 158 | 98 | 63 | | | | | | | |
| OMV-SP21.5-3D | 21.5 | | | 64.5 | | | | | | | |
| OMV-SP22-3D | 22 | 161 | 101 | 66 | | | | | | | |
| OMV-SP22.5-3D | 22.5 | | | 67.5 | | | | | | | |
| OMV-SP23-3D | 23 | 164 | 104 | 69 | | | | | | | |
| OMV-SP23.5-3D | 23.5 | | | 70.5 | | | | | | | |
| OMV-SP24-3D | 24 | 167 | 107 | 72 | | | | | | | |
| OMV-SP24.5-3D | 24.5 | | | 73.5 | | | | | | | |
| OMV-SP25-3D | 25 | 32 | | | SPMG 07T308 | M2.5*7.5 | T8 | | | | |
| OMV-SP25.5-3D | 25.5 | | | | | | | | 170 | 110 | 75 |
| OMV-SP26-3D | 26 | | | | | | | | | | 76.5 |
| OMV-SP26.5-3D | 26.5 | | | | | | | | 173 | 113 | 78 |
| OMV-SP27-3D | 27 | | | | | | | | | | 79.5 |
| OMV-SP27.5-3D | 27.5 | | | | | | | | 176 | 116 | 81 |
| OMV-SP28-3D | 28 | | | | | | | | | | 82.5 |
| OMV-SP28.5-3D | 28.5 | | | | | | | | 179 | 119 | 84 |
| OMV-SP29-3D | 29 | | | | | | | | | | 85.5 |
| OMV-SP29.5-3D | 29.5 | | | | | | | | 182 | 122 | 87 |
| OMV-SP30-3D | 30 | | | | | | | | | | 88.5 |
| OMV-SP30.5-3D | 30.5 | | | | | | | | 185 | 125 | 90 |
| OMV-SP31-3D | 31 | | | | | | | | | | 91.5 |
| OMV-SP31.5-3D | 31.5 | | | | | | | | 188 | 128 | 93 |
| OMV-SP32-3D | 32 | 94.5 | | | | | | | | | |
| OMV-SP32.5-3D | 32.5 | 191 | 131 | 96 | | | | | | | |
| OMV-SP33-3D | 33 | | | 97.5 | | | | | | | |
| OMV-SP33.5-3D | 33.5 | 194 | 134 | 99 | | | | | | | |
| OMV-SP34-3D | 34 | | | 102 | | | | | | | |
| OMV-SP35-3D | 35 | 197 | 137 | 105 | | | | | | | |
| OMV-SP36-3D | 36 | | | 108 | | | | | | | |
| OMV-SP37-3D | 37 | 200 | 140 | 111 | | | | | | | |
| OMV-SP38-3D | 38 | | | 114 | | | | | | | |
| OMV-SP39-3D | 39 | 203 | 143 | 117 | | | | | | | |
| OMV-SP40-3D | 40 | | | 120 | | | | | | | |
| OMV-SP41-3D | 41 | 206 | 146 | 123 | | | | | | | |
| OMV-SP42-3D | 42 | | | 126 | | | | | | | |
| OMV-SP43-3D | 43 | 209 | 149 | 129 | | | | | | | |
| OMV-SP44-3D | 44 | | | 132 | | | | | | | |
| OMV-SP45-3D | 45 | 212 | 152 | 135 | | | | | | | |
| OMV-SP46-3D | 46 | | | 138 | | | | | | | |
| OMV-SP47-3D | 47 | 215 | 155 | 141 | | | | | | | |
| OMV-SP48-3D | 48 | | | 144 | | | | | | | |
| OMV-SP49-3D | 49 | 218 | 158 | 147 | | | | | | | |
| OMV-SP50-3D | 50 | | | 150 | | | | | | | |
| OMV-SP51-3D | 51 | 221 | 161 | 153 | | | | | | | |
| OMV-SP52-3D | 52 | | | 156 | | | | | | | |

SPMG快速鑽頭(3倍)

3X Diameter Drill Depth

| 產品編號 Item Code | 尺寸 Dimensions (mm) | | | | 側固 柄徑 d | 刀片型號 Insert | Screw | Wrench | 牌價 Price | | |
|-------------------|--------------------|-----|-----|-------|------------|----------------|----------|--------|-------------|-----|------|
| | D | L | L1 | L2 | | | | | | | |
| OMV-SP25-3D | 25 | 170 | 110 | 75 | 32 | SPMG 07T308 | M2.5*7.5 | T8 | | | |
| OMV-SP25.5-3D | 25.5 | | | 76.5 | | | | | | | |
| OMV-SP26-3D | 26 | | | 173 | | | | | | 113 | 78 |
| OMV-SP26.5-3D | 26.5 | | | | | | | | | | 79.5 |
| OMV-SP27-3D | 27 | | | 176 | | | | | | 116 | 81 |
| OMV-SP27.5-3D | 27.5 | | | | | | | | | | 82.5 |
| OMV-SP28-3D | 28 | | | 179 | | | | | | 119 | 84 |
| OMV-SP28.5-3D | 28.5 | | | | | | | | | | 85.5 |
| OMV-SP29-3D | 29 | | | 182 | | | | | | 122 | 87 |
| OMV-SP29.5-3D | 29.5 | | | | | | | | | | 88.5 |
| OMV-SP30-3D | 30 | | | 185 | | | | | | 125 | 90 |
| OMV-SP30.5-3D | 30.5 | | | | | | | | | | 91.5 |
| OMV-SP31-3D | 31 | | | 188 | | | | | | 128 | 93 |
| OMV-SP31.5-3D | 31.5 | | | | | | | | | | 94.5 |
| OMV-SP32-3D | 32 | 191 | 131 | 96 | | | | | | | |
| OMV-SP32.5-3D | 32.5 | | | 97.5 | | | | | | | |
| OMV-SP33-3D | 33 | 194 | 134 | 99 | | | | | | | |
| OMV-SP33.5-3D | 33.5 | | | 100.5 | | | | | | | |
| OMV-SP34-3D | 34 | 197 | 137 | 102 | | | | | | | |
| OMV-SP35-3D | 35 | | | 105 | | | | | | | |
| OMV-SP36-3D | 36 | 200 | 140 | 108 | | | | | | | |
| OMV-SP37-3D | 37 | | | 111 | | | | | | | |
| OMV-SP38-3D | 38 | 203 | 143 | 114 | | | | | | | |
| OMV-SP39-3D | 39 | | | 117 | | | | | | | |
| OMV-SP40-3D | 40 | 206 | 146 | 120 | | | | | | | |
| OMV-SP41-3D | 41 | | | 123 | | | | | | | |
| OMV-SP42-3D | 42 | 209 | 149 | 126 | | | | | | | |
| OMV-SP43-3D | 43 | | | 129 | | | | | | | |
| OMV-SP44-3D | 44 | 212 | 152 | 132 | | | | | | | |
| OMV-SP45-3D | 45 | | | 135 | | | | | | | |
| OMV-SP46-3D | 46 | 215 | 155 | 138 | | | | | | | |
| OMV-SP47-3D | 47 | | | 141 | | | | | | | |
| OMV-SP48-3D | 48 | 218 | 158 | 144 | | | | | | | |
| OMV-SP49-3D | 49 | | | 147 | | | | | | | |
| OMV-SP50-3D | 50 | 221 | 161 | 150 | | | | | | | |
| OMV-SP51-3D | 51 | | | 153 | | | | | | | |
| OMV-SP52-3D | 52 | 226 | 166 | 156 | | | | | | | |
| | | | | 156 | | | | | | | |

(A) 銑刀
ENDMILLS

(B) 鑽頭
DRILLS

(C) 絞刀
REAMERS

(D) 絲攻
TAPS

(E) 刀桿/刀盤
MILLING CUTTERS

(F) 刀片
INSERTS

(A) 銑刀
ENDMILLS

(B) 鑽頭
DRILLS

(C) 絞刀
REAMERS

(D) 絲攻
TAPS

(E) 刀桿/刀盤
MILLING CUTTERS

(F) 刀片
INSERTS

SPMG快速鑽頭(3倍)

3X Diameter Drill Depth

| 產品編號 Item Code | 尺寸 Dimensions (mm) | | | | 側固 柄徑 d | 刀片型號 Insert | Screw | Wrench | 牌價 Price |
|-------------------|--------------------|-----|-----|-----|------------|----------------|--------|--------|-------------|
| | D | L | L1 | L2 | | | | | |
| OMV-SP53-3D | 53 | 269 | 199 | 159 | 40 | SPMG 090408 | M3.5*8 | T15 | |
| OMV-SP54-3D | 54 | 272 | 202 | 162 | | | | | |
| OMV-SP55-3D | 55 | 275 | 205 | 165 | | | | | |
| OMV-SP56-3D | 56 | 278 | 208 | 168 | | | | | |
| OMV-SP57-3D | 57 | 281 | 211 | 171 | | | | | |
| OMV-SP58-3D | 58 | 284 | 214 | 174 | | | | | |
| OMV-SP59-3D | 59 | 287 | 217 | 177 | | | | | |
| OMV-SP60-3D | 60 | 290 | 220 | 180 | | | | | |
| OMV-SP61-3D | 61 | 293 | 223 | 183 | | | | | |
| OMV-SP62-3D | 62 | 296 | 226 | 186 | | | | | |
| OMV-SP63-3D | 63 | 299 | 229 | 189 | | | | | |
| OMV-SP64-3D | 64 | 302 | 232 | 192 | | | | | |
| OMV-SP65-3D | 65 | 305 | 235 | 195 | | | | | |

SPMG快速鑽頭(6倍)

6X Diameter Drill Depth

捨棄式快速鑽頭，有效鑽深為直徑的六倍長
Throw-away high speed drill, the drill depth is six times to the diameter.

標準庫存直徑範圍: $\Phi 21 \sim \Phi 55$

公差(mm): $0 \sim \pm 0.2$, 可依需求配合生產。
Hole tolerance(mm): $0 \sim \pm 0.2$

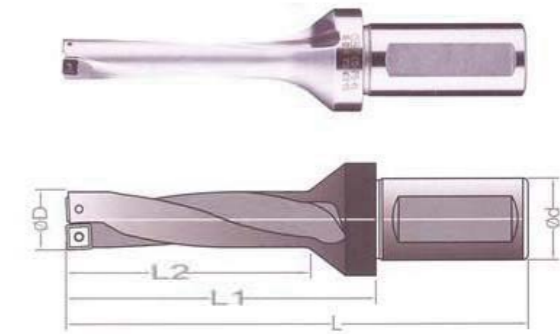

適合加工孔



| 產品編號 Item Code | 尺寸 Dimensions (mm) | | | | 側固 柄徑 d | 刀片型號 Insert | Screw | Wrench | 牌價 Price | | |
|-------------------|--------------------|-----|-----|-----|------------|----------------|----------------|----------------|-------------|-----|--|
| | D | L | L1 | L2 | | | | | | | |
| OMV-SP21-6D | 21 | 221 | 161 | 126 | 32 | SPMG060204 | M2.2*5 | T7 | | | |
| OMV-SP22-6D | 22 | 227 | 167 | 132 | | 32 | SPMG 07T308 | M2.2*5 | T8 | | |
| OMV-SP23-6D | 23 | 233 | 173 | 138 | | | | | | | |
| OMV-SP24-6D | 24 | 239 | 179 | 144 | | | | | | | |
| OMV-SP25-6D | 25 | 245 | 185 | 150 | | | | | | | |
| OMV-SP26-6D | 26 | 251 | 191 | 156 | | | | | | | |
| OMV-SP27-6D | 27 | 257 | 197 | 162 | | | | | | | |
| OMV-SP28-6D | 28 | 263 | 203 | 168 | | | | | | | |
| OMV-SP29-6D | 29 | 269 | 209 | 174 | | | | | | | |
| OMV-SP30-6D | 30 | 275 | 215 | 180 | | | | | | | |
| OMV-SP31-6D | 31 | 281 | 221 | 186 | | | | | | | |
| OMV-SP32-6D | 32 | 287 | 227 | 192 | | | | | | | |
| OMV-SP33-6D | 33 | 308 | 238 | 198 | | | 40 | SPMG 090408 | M3.5*8 | T15 | |
| OMV-SP34-6D | 34 | 314 | 244 | 204 | | | | | | | |
| OMV-SP35-6D | 35 | 320 | 250 | 210 | | | | | | | |
| OMV-SP36-6D | 36 | 326 | 256 | 216 | | | | | | | |
| OMV-SP37-6D | 37 | 332 | 262 | 222 | | | | | | | |
| OMV-SP38-6D | 38 | 338 | 268 | 228 | | | | | | | |
| OMV-SP39-6D | 39 | 344 | 274 | 234 | | | | | | | |
| OMV-SP40-6D | 40 | 350 | 280 | 240 | | | | | | | |
| OMV-SP41-6D | 41 | 356 | 286 | 246 | | | | | | | |
| OMV-SP42-6D | 42 | 362 | 292 | 252 | | | | | | | |
| OMV-SP43-6D | 43 | 368 | 298 | 258 | | | | | | | |
| OMV-SP44-6D | 44 | 374 | 304 | 264 | | | | | | | |
| OMV-SP45-6D | 45 | 380 | 310 | 270 | | | | | | | |
| | | | | | | SPMG 110408 | | M4.0*10 | | | |
| | | | | | | SPMG 110408 | | M5.0*11 | T20 | | |
| | | | | | | | | | | | |
| | | | | | | | | | | | |

(A) 銑刀
ENDMILLS
(B) 鑽頭
DRILLS
(C) 絞刀
REAMERS
(D) 絲攻
TAPS
(E) 刀桿/刀盤
MILLING CUTTERS
(F) 刀片
INSERTS

(A) 銑刀
ENDMILLS
(B) 鑽頭
DRILLS
(C) 絞刀
REAMERS
(D) 絲攻
TAPS
(E) 刀桿/刀盤
MILLING CUTTERS
(F) 刀片
INSERTS

SPMG快速鑽頭(6倍)

6X Diameter Drill Depth

| 產品編號 Item Code | 尺寸 Dimensions (mm) | | | | 側固 柄徑 d | 刀片型號 Insert | Screw | Wrench | 牌價 Price |
|-------------------|--------------------|-----|-----|-----|------------|----------------|----------|--------|-------------|
| | D | L | L1 | L2 | | | | | |
| OMV-SP46-6D | 46 | 386 | 316 | 276 | 40 | SPMG 140512 | M5.0*11 | T20 | |
| OMV-SP47-6D | 47 | 392 | 322 | 282 | | | | | |
| OMV-SP48-6D | 48 | 398 | 328 | 288 | | | | | |
| OMV-SP49-6D | 49 | 404 | 334 | 294 | | SPMG 07T308 | M2.5*7.5 | T8 | |
| OMV-SP50-6D | 50 | 410 | 340 | 300 | | | | | |
| OMV-SP51-6D | 51 | 416 | 346 | 306 | | | | | |
| OMV-SP52-6D | 52 | 422 | 352 | 312 | | SPMG 090408 | M3.5*8 | T15 | |
| OMV-SP53-6D | 53 | 428 | 358 | 318 | | | | | |
| OMV-SP54-6D | 54 | 434 | 364 | 324 | | | | | |
| OMV-SP55-6D | 55 | 440 | 370 | 330 | | | | | |

(A) 銑刀
ENDMILLS

(B) 鑽頭
DRILLS

(C) 絞刀
REAMERS

(D) 絲攻
TAPS

(E) 刀桿/刀盤
MILLING CUTTERS

(F) 刀片
INSERTS

(A) 銑刀
ENDMILLS

(B) 鑽頭
DRILLS

(C) 絞刀
REAMERS

(D) 絲攻
TAPS

(E) 刀桿/刀盤
MILLING CUTTERS

(F) 刀片
INSERTS

(A) 銑刀
ENDMILLS
(B) 鑽頭
DRILLS
(C) 絞刀
REAMERS
(D) 絲攻
TAPS
(E) 刀桿/刀盤
MILLING CUTTERS
(F) 刀片
INSERTS

(A) 銑刀
ENDMILLS
(B) 鑽頭
DRILLS
(C) 絞刀
REAMERS
(D) 絲攻
TAPS
(E) 刀桿/刀盤
MILLING CUTTERS
(F) 刀片
INSERTS

檢測報告 Test Report

I. INSPECTION RESULTS

| Tool overhang : 10 multiples of the Tool Diameter | | | |
|---|---|--------------|--|
| ITEM | TITLE | TARGET VALUE | INSPECTION RESULTS |
| A | Distance range of inner bore depth of the workpiece | 0~320mm | Tool overhang: 320mm Machining depth of the internal diameter of the workpiece in the axial direction: 80.79mm |
| B | Surface roughness of the workpiece (Ra) | 0.7µm | 0.57µm |
| C | Machining roundness of the workpiece | ± 0.02mm | At the machining depth 20mm, the roundness is 0.00465mm. At the machining depth 40mm, the roundness is 0.00230mm. At the machining depth 60mm, the roundness is 0.00235mm. |

| Tool overhang : 372 mm | | |
|------------------------|---|--|
| ITEM | TITLE | INSPECTION RESULTS |
| A | Distance range of inner bore depth of the workpiece | Tool overhang: 372mm Machining depth of the internal diameter of the workpiece in the axial direction: 101mm |
| B | Surface roughness of the workpiece (Ra) | 2.22µm |
| C | Machining roundness of the workpiece | At the machining depth 25mm, the roundness is 0.01235mm. At the machining depth 50mm, the roundness is 0.0071mm. At the machining depth 75mm, the roundness is 0.0072mm. |

👍 抗震倍數 6~14 倍

材質：藍十字合金鋼
HRC 硬度 42 度

台灣專利：M385422
美國專利：US8371776

Y 型單水孔抗震外徑牙刀

Y-type Coolant Hole Anti-vibration External Holder

1. 制震器：刀片壽命提升
2. 拆裝快速：3 圈即可拆裝刀片
3. 中心出水：水噴刀尖斷屑槽的位置有效冷卻、排屑效果優異

MER-2525M16- 0°
牌價：MCKNR-25

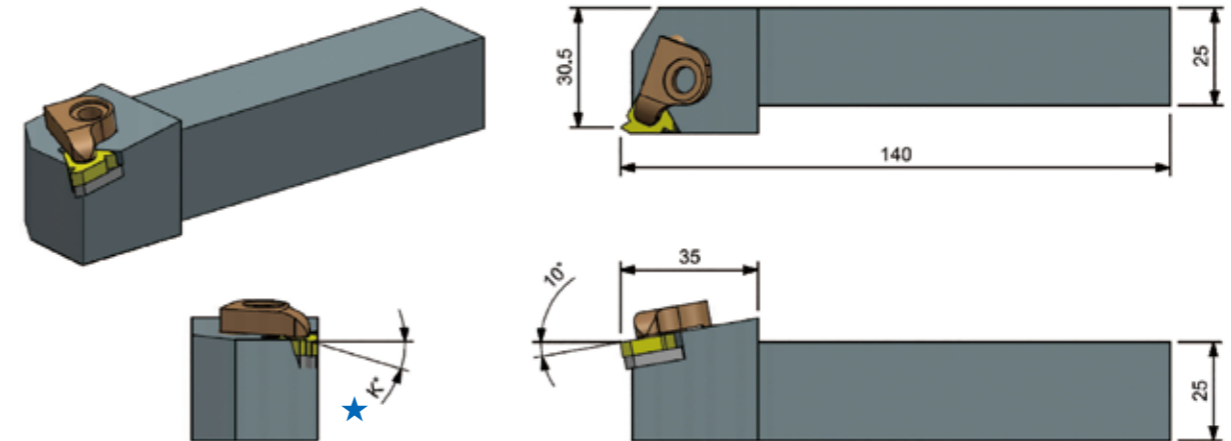

| 刀片型號 Insert | M.C.T 磁浮刀片 M.C.T Insert Coated | | | | 配件 Parts | | | | | 扳手 Key |
|----------------|-----------------------------------|----------|----------|---------|-------------|----|------|----------|----|-----------|
| | VMM 4010 | WMM 4720 | VMM 4720 | WMM 415 | | | | | | |
| ER16 | | | | | D-ER | M6 | AD01 | GMG-321R | M4 | LW050 |

★旋角 K 有 0°、0.5°、1°、1.5°、2°、2.5°、3°、3.5°

Compare of Vibration Amplitude 震幅比較

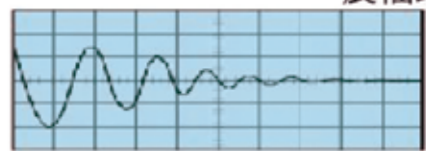

Monkula anti-vibration cutters

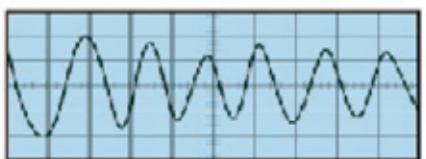

Other cutters without anti-vibration

Struction of Damper System

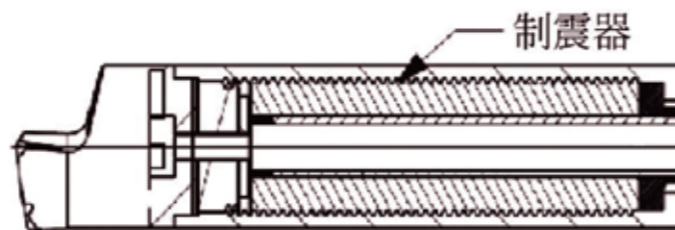

Y 型單水孔抗震外徑車刀

Y-type Coolant Hole
Anti-vibration Turning Tool Holder

1. 制震器：刀片壽命提升
2. 拆裝快速：3 圈即可拆裝刀片
3. 中心出水：水噴刀尖斷屑槽的位置有效冷卻、排屑效果優異

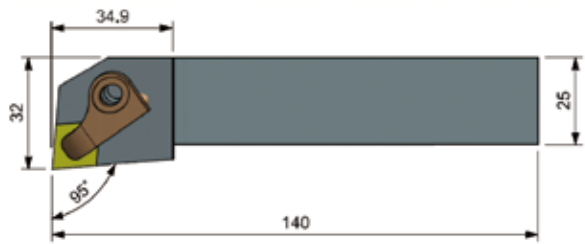

MCLNR-2525M12
牌價：MCKNR-25

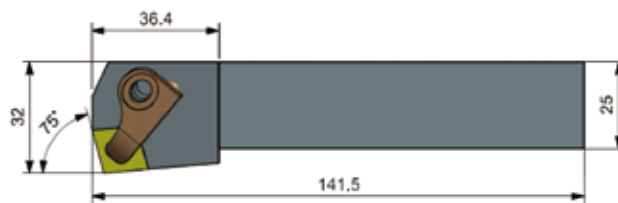

MCKNR-2525M12
牌價：MCKNR-25

| 刀片型號 Insert | M.C.T 磁浮刀片 M.C.T Insert Coated | | | | 配件 Parts | | | | | | 扳手 Key |
|-----------------|-----------------------------------|-------------|-------------|------------|----------------|----|------|-----------|----|-------|-----------|
| | VMM 4010 | WMM 4720 | VMM 4720 | WMM 415 | | | | | | | |
| CNMG1204 | | | | | D-CLN D-CKN | M6 | AD01 | GMC-422-4 | M5 | LW050 | |

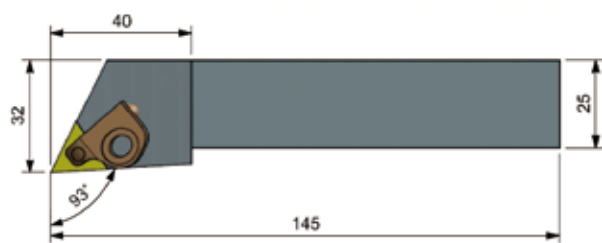

MTJNR-2525M16
牌價：MCKNR-25

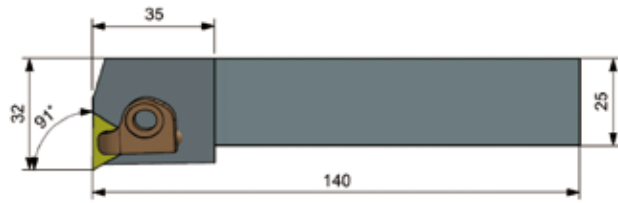

MTFNR-2525M16
牌價：MCKNR-25

| 刀片型號 Insert | M.C.T 磁浮刀片 M.C.T Insert Coated | | | | 配件 Parts | | | | | | 扳手 Key |
|-----------------|-----------------------------------|-------------|-------------|------------|----------------|----|------|-----------|----|-------|-----------|
| | VMM 4010 | WMM 4720 | VMM 4720 | WMM 415 | | | | | | | |
| TNMG1604 | | | | | D-TJN D-TFN | M6 | AD01 | GMT-321-1 | M4 | LW050 | |

Y 型單水孔抗震外徑車刀

Y-type Coolant Hole
Anti-vibration Turning Tool Holder

1. 制震器：刀片壽命提升
2. 拆裝快速：3 圈即可拆裝刀片
3. 中心出水：水噴刀尖斷屑槽的位置有效冷卻、排屑效果優異

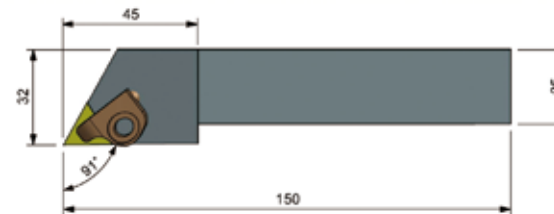

MTGNR-2525M16
牌價：MCKNR-25

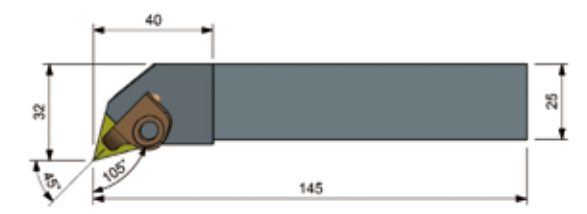

MTQNR-2525M16
牌價：MCKNR-25

| 刀片型號 Insert | M.C.T 磁浮刀片 M.C.T Insert Coated | | | | 配件 Parts | | | | | | 扳手 Key |
|-----------------|-----------------------------------|-------------|-------------|------------|----------------|----|------|-----------|----|-------|-----------|
| | VMM 4010 | WMM 4720 | VMM 4720 | WMM 415 | | | | | | | |
| TNMG1604 | | | | | D-TGN D-TQN | M6 | AD01 | GMT-321-1 | M4 | LW050 | |

MVJNR-2525M16
牌價：MCKNR-25

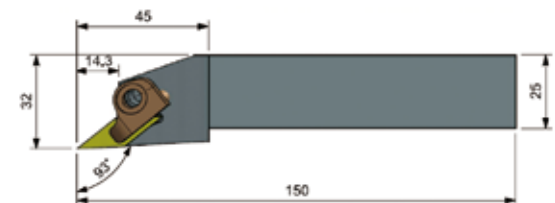

| 刀片型號 Insert | M.C.T 磁浮刀片 M.C.T Insert Coated | | | | 配件 Parts | | | | | | 扳手 Key |
|-----------------|-----------------------------------|-------------|-------------|------------|-------------|----|------|---------|----|-------|-----------|
| | VMM 4010 | WMM 4720 | VMM 4720 | WMM 415 | | | | | | | |
| VNMG1604 | | | | | D-VJN | M6 | AD01 | GMV-322 | M4 | LW050 | |

MWLNR-2525M08
牌價：MCKNR-25

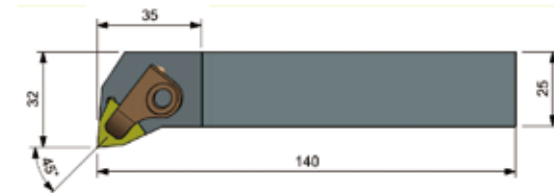

| 刀片型號 Insert | M.C.T 磁浮刀片 M.C.T Insert Coated | | | | 配件 Parts | | | | | | 扳手 Key |
|-----------------|-----------------------------------|-------------|-------------|------------|-------------|----|------|-----------|----|-------|-----------|
| | VMM 4010 | WMM 4720 | VMM 4720 | WMM 415 | | | | | | | |
| WNMG0804 | | | | | D-WLN | M6 | AD01 | GMW-422-1 | M4 | LW050 | |

(A) 銑刀
ENDMILLS
(B) 鑽頭
DRILLS
(C) 絞刀
REAMERS
(D) 絲攻
TAPS
(E) 刀桿/刀盤
MILLING CUTTERS
(F) 刀片
INSERTS

(A) 銑刀
ENDMILLS
(B) 鑽頭
DRILLS
(C) 絞刀
REAMERS
(D) 絲攻
TAPS
(E) 刀桿/刀盤
MILLING CUTTERS
(F) 刀片
INSERTS

雙水孔抗震切斷刀

Double Coolant Hole
Anti-vibration Groove Tool Holder

1. 強力出水，水噴刀尖
2. 壽命提升，產能提升
3. 配管方便，切屑良好

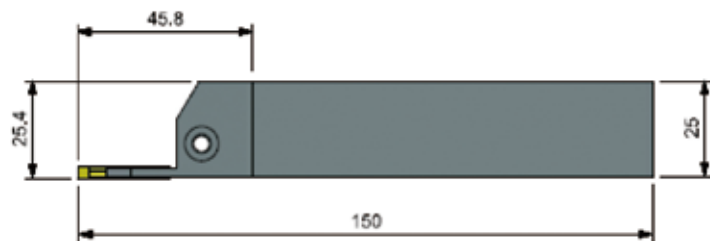

M25R0025-2525M
牌價：MCKNR-25

| 產品編號 Item Code | 刀片型號 Insert | M.C.T 磁浮刀片 M.C.T Insert Coated | | | | 配件 Parts | 扳手 Key |
|---------------------|----------------|-----------------------------------|-------------|-------------|------------|-------------|-----------|
| | | VMM 4010 | WMM 4720 | VMM 4720 | WMM 415 | | |
| M25R0025-2525M-GX24 | GX24-2E3.00 | | | | | M5 | LW050 |
| M25R0021-2525M-GX24 | GX24-2E3.00 | | | | | M5 | LW050 |
| M25R0012-2525M-GX16 | GX16-2E3.00 | | | | | M5 | LW050 |

建議加工條件：VC 120~150 / F 0.12~0.15

刀片槽寬 3mm (4mm可選) 插槽深度 25mm, 21mm, 12mm
Insert Width 3mm (4mm Optional) Groove Depth 25mm, 21mm, 12mm

固定式粗搪刀

FIXED ROUGH BORING BARS

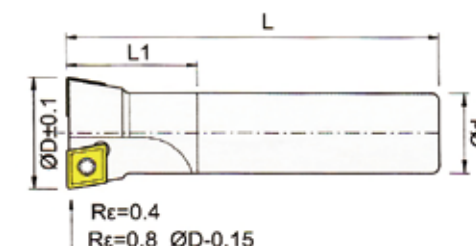

| 產品編號 Item Code | L | 牌價 Price | 產品編號 Item Code | L | 牌價 Price | 尺寸 Dimensions (mm) | | | 刃數 Teeth | 刀片 型號 Insert |
|-------------------|-----|------------------|-------------------|------|-------------|-----------------------|----|----------------|-------------|--------------------|
| | | | | | | D Re=0.4 | d | L1 | | |
| OBV-TB008S16-120 | 120 | | | 160 | | 7.8 | 16 | 30 | 1 | CC.. 060204 |
| OBV-TB009S16-120 | | | | | 8.8 | | | | | |
| OBV-TB010S16-120 | | | OBV-TB010S16-160 | | 9.8 | | | | | |
| OBV-TB011S16-120 | | | OBV-TB011S16-160 | | 10.8 | | | | | |
| OBV-TB012S16-120 | | | OBV-TB012S16-160 | | 11.8 | | | | | |
| OBV-TB013S16-120 | | | OBV-TB013S16-160 | | 12.8 | | | | | |
| OBV-TB014S16-120 | | OBV-TB014S16-160 | 13.8 | 160 | 16 | 30 | 2 | CC.. 060204 | | |
| OBV-TB015S16-120 | | OBV-TB015S16-160 | 14.8 | | | | | | | |
| OBV-TB016S16-120 | | OBV-TB016S16-160 | 15.8 | | | | | | | |
| OBV-TB017S16-120 | | OBV-TB017S16-160 | 16.8 | | | | | | | |
| OBV-TB018S16-120 | | OBV-TB018S16-160 | 17.8 | | | | | | | |
| OBV-TB019S16-120 | | OBV-TB019S16-160 | 18.8 | | | | | | | |
| OBV-TB020S16-120 | | OBV-TB020S16-160 | 19.8 | | | | | | | |
| OBV-TB021S16-120 | | OBV-TB021S16-160 | 20.8 | | | | | | | |
| OBV-TB022S16-120 | | OBV-TB022S16-160 | 21.8 | | | | | | | |
| OBV-TB023S20-130 | 130 | | OBV-TB023S20-160 | | | | | | 22.8 | 20 |
| OBV-TB024S20-130 | | | OBV-TB024S20-160 | 23.8 | | | | | | |
| OBV-TB025S20-130 | | | OBV-TB025S20-160 | 24.8 | | | | | | |
| OBV-TB026S20-130 | 130 | | OBV-TB026S20-160 | 25.8 | 20 | 30 | 2 | CC.. 09T304 | | |
| OBV-TB027S20-130 | | | OBV-TB027S20-160 | 26.8 | | | | | | |
| OBV-TB028S20-130 | | | OBV-TB028S20-160 | 27.8 | | | | | | |
| OBV-TB029S20-130 | | | OBV-TB029S20-160 | 28.8 | | | | | | |
| OBV-TB029S25-160 | 160 | | OBV-TB029S25-200 | 28.8 | 25 | 40 | 2 | CC.. 09T304 | | |
| OBV-TB030S25-160 | | | OBV-TB030S25-200 | 29.8 | | | | | | |
| OBV-TB031S25-160 | | | OBV-TB031S25-200 | 30.8 | | | | | | |

(A) 銑刀
ENDMILLS
(B) 鑽頭
DRILLS
(C) 絞刀
REAMERS
(D) 絲攻
TAPS
(E) 刀桿/刀盤
MILLING CUTTERS
(F) 刀片
INSERTS

(A) 銑刀
ENDMILLS
(B) 鑽頭
DRILLS
(C) 絞刀
REAMERS
(D) 絲攻
TAPS
(E) 刀桿/刀盤
MILLING CUTTERS
(F) 刀片
INSERTS

固定式粗搪刀



FIXED ROUGH BORING BARS

| 產品編號 Item Code | L | 牌價 Price | 產品編號 Item Code | L | 牌價 Price | 尺寸 Dimensions (mm) | | | 刃數 Teeth | 刀片 型號 Insert | |
|-------------------|-----|------------------|-------------------|------|------------------|--------------------------|----|----|-------------|--------------------|--|
| | | | | | | D Re=0.4 | d | L1 | | | |
| OBV-TB032S25-160 | 160 | | OBV-TB032S25-200 | 200 | | 31.8 | 25 | 40 | 2 | CC.. 09T304 | |
| OBV-TB033S25-160 | | | OBV-TB033S25-200 | | | 32.8 | | | | | |
| OBV-TB034S25-160 | | | OBV-TB034S25-200 | | | 33.8 | | | | | |
| OBV-TB035S25-160 | | | OBV-TB035S25-200 | | | 34.8 | | | | | |
| OBV-TB036S25-160 | | | OBV-TB036S25-200 | | | 35.8 | | | | | |
| OBV-TB037S25-160 | | | OBV-TB037S25-200 | | | 36.8 | | | | | |
| OBV-TB038S25-160 | | | OBV-TB038S25-200 | | | 37.8 | | | | | |
| OBV-TB039S25-160 | | | OBV-TB039S25-200 | | | 38.8 | | | | | |
| OBV-TB040S25-160 | | | OBV-TB040S25-200 | | | 39.8 | | | | | |
| OBV-TB035S32-160 | | 160 | | | OBV-TB035S32-200 | 200 | | | | | |
| OBV-TB036S32-160 | | | OBV-TB036S32-200 | | 35.8 | | 60 | | | | |
| OBV-TB037S32-160 | | | OBV-TB037S32-200 | | 36.8 | | 40 | | | | |
| OBV-TB038S32-160 | | | OBV-TB038S32-200 | | 37.8 | | 45 | | | | |
| OBV-TB039S32-160 | | | OBV-TB039S32-200 | | 38.8 | | | | | | |
| OBV-TB040S32-160 | | OBV-TB040S32-200 | | 39.8 | | | | | | | |
| OBV-TB041S32-200 | 200 | | OBV-TB041S32-250 | 250 | | 40.8 | 32 | 45 | 2 | CC.. 09T304 | |
| OBV-TB042S32-200 | | | OBV-TB042S32-250 | | | 41.8 | | | | | |
| OBV-TB043S32-200 | | | OBV-TB043S32-250 | | | 42.8 | | | | | |
| OBV-TB044S32-200 | | | OBV-TB044S32-250 | | | 43.8 | | | | | |
| OBV-TB045S32-200 | | | OBV-TB045S32-250 | | | 44.8 | | | | | |
| OBV-TB046S32-200 | | | OBV-TB046S32-250 | | | 45.8 | | | | | |
| OBV-TB047S32-200 | | | OBV-TB047S32-250 | | | 46.8 | | | | | |
| OBV-TB048S32-200 | | | OBV-TB048S32-250 | | | 47.8 | | | | | |
| OBV-TB049S32-200 | | | OBV-TB049S32-250 | | | 48.8 | | | | | |
| OBV-TB050S32-200 | | | OBV-TB050S32-250 | | | 49.8 | | | | | |
| OBV-TB051S32-200 | 200 | | OBV-TB051S32-250 | 250 | | 50.8 | 32 | 45 | 2 | CC.. 09T304 | |
| OBV-TB052S32-200 | | | OBV-TB052S32-250 | | | 51.8 | | | | | |
| OBV-TB053S32-200 | | | OBV-TB053S32-250 | | | 52.8 | | | | | |
| OBV-TB054S32-200 | | | OBV-TB054S32-250 | | | 53.8 | | | | | |
| OBV-TB055S32-200 | | | OBV-TB055S32-250 | | | 54.8 | | | | | |
| OBV-TB056S32-200 | | | OBV-TB056S32-250 | | | 55.8 | | | | | |
| OBV-TB057S32-200 | | | OBV-TB057S32-250 | | | 56.8 | | | | | |

固定式粗搪刀

FIXED ROUGH BORING BARS

| 產品編號 Item Code | L | 牌價 Price | 產品編號 Item Code | L | 牌價 Price | 尺寸 Dimensions (mm) | | | 刃數 Teeth | 刀片 型號 Insert | |
|-------------------|-----|-------------|-------------------|-----|------------------|--------------------------|----|----|-------------|--------------------|----|
| | | | | | | D Re=0.4 | d | L1 | | | |
| OBV-TB038S25-250 | 250 | | OBV-TB038S25-300 | 300 | | 37.8 | 25 | 40 | 2 | CC.. 09T304 | |
| OBV-TB039S25-250 | | | OBV-TB039S25-300 | | | 38.8 | | | | | |
| OBV-TB040S25-250 | | | OBV-TB040S25-300 | | | 39.8 | | | | | |
| OBV-TB035S32-250 | 250 | | OBV-TB035S32-300 | 300 | | 34.8 | 32 | 50 | 2 | CC.. 09T304 | |
| OBV-TB036S32-250 | | | OBV-TB036S32-300 | | | 35.8 | | | | | 60 |
| OBV-TB037S32-250 | | | OBV-TB037S32-300 | | | 36.8 | | | | | 40 |
| OBV-TB038S32-250 | | | OBV-TB038S32-300 | | | 37.8 | | | | | 45 |
| OBV-TB039S32-250 | | | OBV-TB039S32-300 | | | 38.8 | | | | | |
| OBV-TB040S32-250 | | | OBV-TB040S32-300 | | | 39.8 | | | | | |
| OBV-TB041S32-300 | | 300 | | | OBV-TB041S32-350 | 350 | | | | | |
| OBV-TB042S32-300 | | | OBV-TB042S32-350 | | 41.8 | | | | | | |
| OBV-TB043S32-300 | | | OBV-TB043S32-350 | | 42.8 | | | | | | |
| OBV-TB044S32-300 | | | OBV-TB044S32-350 | | 43.8 | | | | | | |
| OBV-TB045S32-300 | | | OBV-TB045S32-350 | | 44.8 | | | | | | |
| OBV-TB046S32-300 | | | OBV-TB046S32-350 | | 45.8 | | | | | | |
| OBV-TB047S32-300 | | | OBV-TB047S32-350 | | 46.8 | | | | | | |
| OBV-TB048S32-300 | | | OBV-TB048S32-350 | | 47.8 | | | | | | |
| OBV-TB049S32-300 | | | OBV-TB049S32-350 | | 48.8 | | | | | | |
| OBV-TB050S32-300 | | | OBV-TB050S32-350 | | 49.8 | | | | | | |
| OBV-TB051S32-300 | 300 | | OBV-TB051S32-350 | 350 | | 50.8 | 32 | 45 | 2 | CC.. 09T304 | |
| OBV-TB052S32-300 | | | OBV-TB052S32-350 | | | 51.8 | | | | | |
| OBV-TB053S32-300 | | | OBV-TB053S32-350 | | | 52.8 | | | | | |
| OBV-TB054S32-300 | | | OBV-TB054S32-350 | | | 53.8 | | | | | |
| OBV-TB055S32-300 | | | OBV-TB055S32-350 | | | 54.8 | | | | | |
| OBV-TB056S32-300 | | | OBV-TB056S32-350 | | | 55.8 | | | | | |
| OBV-TB057S32-300 | | | OBV-TB057S32-350 | | | 56.8 | | | | | |

| 刀片型號 Insert | Screw  | Wrench  | 牌價 Price | |
|----------------|--|---|----------|--------|
| | | | WMM4020 | VMM415 |
| CC..060204 | MS2506A | T09 | | |
| CC..09T304 | MS4011A | T15 | | |

(A) 銑刀
ENDMILLS

(B) 鑽頭
DRILLS

(C) 絞刀
REAMERS

(D) 絲攻
TAPS

(E) 刀桿/刀盤
MILLING CUTTERS

(F) 刀片
INSERTS

(A) 銑刀
ENDMILLS

(B) 鑽頭
DRILLS

(C) 絞刀
REAMERS

(D) 絲攻
TAPS

(E) 刀桿/刀盤
MILLING CUTTERS

(F) 刀片
INSERTS

小徑搪刀

BORING SHANK

小徑搪刀

BORING SHANK

(A) 銑刀
ENDMILLS
(B) 鑽頭
DRILLS
(C) 絞刀
REAMERS
(D) 絲攻
TAPS
(E) 刀桿/刀盤
MILLING CUTTERS
(F) 刀片
INSERTS

(A) 銑刀
ENDMILLS
(B) 鑽頭
DRILLS
(C) 絞刀
REAMERS
(D) 絲攻
TAPS
(E) 刀桿/刀盤
MILLING CUTTERS
(F) 刀片
INSERTS

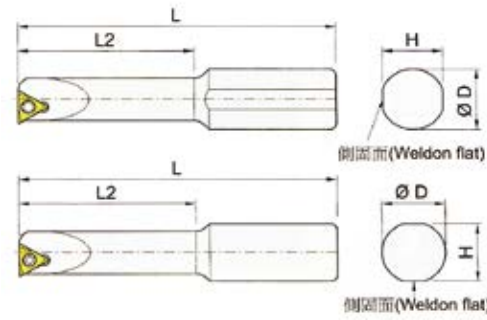
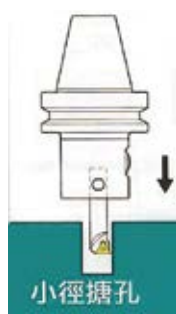

| 產品編號 1 - Item Code | 產品編號 2 - Item Code | 尺寸 Dimensions (mm) | | | | | 刀片型號 Insert | Screw | Wrench | 牌價 Price |
|-----------------------|-----------------------|--|-------|----|----|---|----------------|---------|--------|-------------|
| | | D | Range | L | L2 | H | | | | |
| OBV-BH1008-32 | | 10 | 8-10 | 64 | 32 | 9 | WC..0201 | MS2004A | T06 | |
| OBV-BH1010-40 | | | 10-12 | 72 | 40 | | | MS2005A | | |
| | OBV-BJ10B06-12 | | 6-8 | 64 | 12 | | WC..0601 | MS2003A | | |
| | OBV-BJ10B06-24 | | 6-8 | 64 | 24 | | | MS2004A | | |
| OBV-BJ1008-32 | OBV-BJ10B08-32 | | 8-10 | 64 | 32 | | TB..0601 | MS2005A | | |
| OBV-BJ1010-40 | OBV-BJ10B10-40 | | 10-12 | 72 | 40 | | | MS2004A | | |
| OBV-BJ1012-45 | OBV-BJ10B12-45 | | 12-16 | 77 | 22 | | TP..0902 | MS2506A | | |
| OBV-BJ1016-45 | OBV-BJ10B16-45 | | 16-20 | 77 | 22 | | | MS3008A | | |
| OBV-BJ1020-45 | OBV-BJ10B20-45 | | 20-25 | 77 | 25 | | TP..1103 | MS3008A | | |
| | | | 20-25 | 77 | 27 | | | | | |
| ■ OBV-BH10*S | | OBV-BH1008-32, OBV-BH1010-40, OBV-BJ1012-45, OBV-BJ1016-45, OBV-BJ1020-45 | | | | | | | | |
| ■ OBV-BJ10*S | | OBV-BJ1008-32, OBV-BJ1010-40, OBV-BJ1012-45, OBV-BJ1016-45, OBV-BJ1020-45 | | | | | | | | |
| | ■ OBV-BJ10B*S | OBV-BJ10B06-24, OBV-BJ10B08-32, OBV-BJ10B10-40, OBV-BJ10B12-45, OBV-BJ10B16-45, OBV-BJ10B20-45 | | | | | | | | |

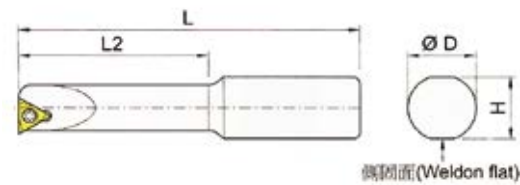

■ 表盒裝 Suite

| 產品編號 Item Code | 尺寸 Dimensions (mm) | | | | | 刀片型號 Insert | Screw | Wrench | 牌價 Price | | | | |
|-------------------|--------------------|--|----|----|----|----------------|---------|--------|-------------|--|--|--|--|
| | D | Range | L | L2 | H | | | | | | | | |
| OBV-BJ12B06-12 | 12 | 6-8 | 64 | 12 | 11 | WB..0601 | MS2003A | T06 | | | | | |
| OBV-BJ12B06-24 | | 6-8 | 64 | 24 | | | MS2004A | | | | | | |
| OBV-BJ12B08-32 | | 6-10 | 64 | 32 | | TB..0601 | MS2005A | | | | | | |
| OBV-BJ12B10-40 | | 10-12 | 72 | 40 | | | MS2004A | | | | | | |
| OBV-BJ12B12-45 | | 12-16 | 77 | 45 | | TP..0902 | MS2506A | | | | | | |
| OBV-BJ12B16-45 | | 16-20 | 77 | 22 | | | MS3008A | | | | | | |
| OBV-BJ12B20-45 | | 20-25 | 77 | 25 | | TP..0902 | MS3008A | | | | | | |
| OBV-BJ12B25-45 | | 25-30 | 77 | 25 | | | | | | | | | |
| ■ OBV-BJ12B*S | | OBV-BJ12B06-24, OBV-BJ12B08-32, OBV-BJ12B10-40, OBV-BJ12B12-45, OBV-BJ12B16-45, OBV-BJ12B20-45, OBV-BJ12B25-45 | | | | | | | | | | | |

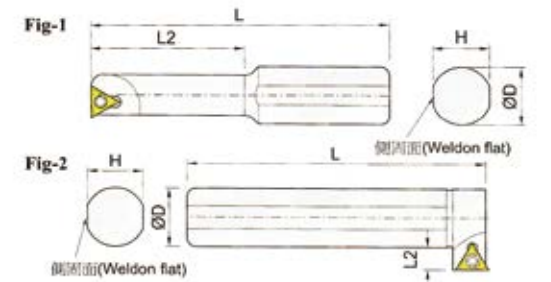
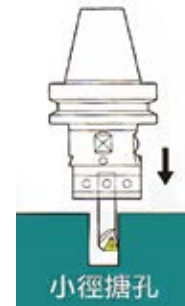

| 產品編號 Item Code | 尺寸 Dimensions (mm) | | | | | | 刀片型號 Insert | Screw | Wrench | 牌價 Price |
|-------------------|--|-------|-----|----|----|----|----------------|---------|--------|-------------|
| | D | Range | L | L2 | H | DN | | | | |
| OBV-BH1806-25 | 18 | 6-8 | 68 | 25 | 17 | 1 | WC..0201 | MS2003A | T06 | |
| OBV-BH1808-32 | | 8-10 | 72 | 32 | | | | MS2004A | | |
| OBV-BH1810-40 | | 10-12 | 80 | 40 | | | | MS2005A | | |
| OBV-BJ1806-12 | | 6-8 | 68 | 12 | | | WB..0601 | MS2003A | | |
| OBV-BJ1806-24 | | 6-8 | 68 | 24 | | | | MS2004A | | |
| OBV-BJ1808-32 | | 8-10 | 72 | 32 | | | TB..0601 | MS2005A | | |
| OBV-BJ1810-40 | | 10-12 | 80 | 40 | | | | MS2506A | | |
| OBV-BJ1812-53 | | 12-16 | 93 | 53 | | | TP..0902 | MS3008A | | |
| OBV-BJ1816-68 | | 16-20 | 108 | 68 | | | | | | |
| OBV-BJ1820-83 | | 20-25 | 123 | 40 | | | TP..1103 | MS3008A | | |
| OBV-BJ1825-90 | 25-30 | 130 | 40 | | | | | | | |
| OBV-BJ1830-90 | 30-35 | 130 | 40 | 2 | | | | | | |
| OBV-BJ-L18-36 | --- | 97 | 8 | | | | | | | |
| ■ OBV-BH18S* | OBV-BH1808-32, OBV-BH1810-40, OBV-BJ1812-53, OBV-BJ1816-68, OBV-BJ1820-83, OBV-BJ1825-90, OBV-BJ1830-90, OBV-BJ-L18-36 | | | | | | | | | |
| ■ OBV-BJ18S* | OBV-BJ1808-32, OBV-BJ1810-40, OBV-BJ1812-53, OBV-BJ1816-68, OBV-BJ1820-83, OBV-BJ1825-90, OBV-BJ1830-90, OBV-BJ-L18-36 | | | | | | | | | |

■ 表盒裝 Suite

| 產品編號 Item Code | 尺寸 Dimensions (mm) | | | | | | 刀片型號 Insert | Screw | Wrench | 牌價 Price |
|-------------------|---|-------|----|----|----|----|----------------|---------|--------|-------------|
| | D | Range | L | L2 | H | DN | | | | |
| OBV-BH2006-25 | 20 | 6-8 | 68 | 25 | 19 | 1 | WC..0201 | MS2003A | T06 | |
| OBV-BH2008-32 | | 8-10 | 74 | 32 | | | | MS2004A | | |
| OBV-BH2010-40 | | 10-12 | 75 | 40 | | | | MS2005A | | |
| OBV-BJ2006-12 | | 6-8 | 68 | 12 | | | WB..0601 | MS2003A | | |
| OBV-BJ2006-24 | | 6-8 | 68 | 24 | | | | MS2004A | | |
| OBV-BJ2008-16 | | 8-10 | 74 | 16 | | | TB..0601 | MS2005A | | |
| OBV-BJ2008-32 | | 8-10 | 74 | 32 | | | | MS2506A | | |
| OBV-BJ2010-20 | | 10-12 | 75 | 20 | | | TP..0902 | MS3008A | | |
| OBV-BJ2010-40 | | 10-12 | 75 | 40 | | | | | | |
| OBV-BJ2012-53 | | 12-16 | 85 | 53 | | | TP..1103 | MS3008A | | |
| OBV-BJ2016-68 | 16-20 | 100 | 68 | | | | | | | |
| OBV-BJ2020-83 | 20-25 | 115 | 83 | 2 | | | | | | |
| OBV-BJ2025-96 | 25-30 | 135 | 40 | | | | | | | |
| OBV-BJ2030-115 | 30-35 | 158 | 40 | | | | | | | |
| OBV-BJ-L20-36 | --- | 97 | 8 | | | | | | | |
| ■ OBV-BH20S* | OBV-BH2008-32, OBV-BH2010-40, OBV-BJ2012-53, OBV-BJ2016-68, OBV-BJ2020-83, OBV-BJ2025-96, OBV-BJ2030-115, OBV-BJ-L20-36 | | | | | | | | | |
| ■ OBV-BJ20S* | OBV-BJ2008-32, OBV-BJ2010-40, OBV-BJ2012-53, OBV-BJ2016-68, OBV-BJ2020-83, OBV-BJ2025-96, OBV-BJ2030-115, OBV-BJ-L20-36 | | | | | | | | | |

小徑搪刀
BORING SHANK

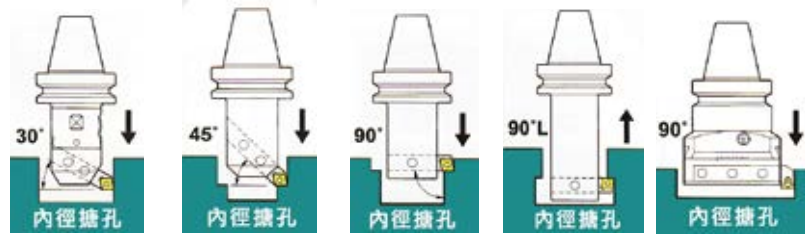

| 刀片形狀 Insert Shape | 產品編號 1 - Item Code | 刀片型號 Insert | 牌價 Price | 產品編號 2 - Item Code | 刀片型號 Insert | 牌價 Price | 尺寸 Dimensions (mm) | | | |
|----------------------|-----------------------|----------------|-------------|-----------------------|----------------|-------------|-----------------------|-----|-----|----|
| | | | | | | | H | W | L | |
| | OBV-CTBS306 | CC..0602.. | | OBV-TSBS306C | TC..0902.. | | 6 | 6 | 55 | |
| | OBV-CTBS308 | CC..0602.. | | OBV-TSBS308C | TC..0902.. | | 8 | 8 | 55 | |
| | OBV-CTBS310 | CC..0602.. | | OBV-TSBS310C | TC..0902.. | | 10 | 10 | 65 | |
| | OBV-CTBS313 | CC..09T3.. | | OBV-TSBS313C | TC..1102.. | | 13 | 13 | 80 | |
| | OBV-CTBS316 | CC..09T3.. | | OBV-TSBS316C | TC..16T3.. | | 16 | 16 | 120 | |
| | OBV-CTBS319 | CC..1204.. | | OBV-TSBS319C | TC..16T3.. | | 19 | 19 | 140 | |
| | OBV-CTBS325 | CC..1204.. | | OBV-TSBS325C | TC..16T3.. | | 25 | 25 | 150 | |
| | | OBV-CTBS406 | CC..0602.. | | OBV-TSBS406C | TC..0902.. | | 6 | 6 | 55 |
| | | OBV-CTBS408 | CC..0602.. | | OBV-TSBS408C | TC..0902.. | | 8 | 8 | 55 |
| | | OBV-CTBS410 | CC..0602.. | | OBV-TSBS410C | TC..0902.. | | 10 | 10 | 65 |
| OBV-CTBS413 | | CC..09T3.. | | OBV-TSBS413C | TC..1102.. | | 13 | 13 | 80 | |
| OBV-CTBS416 | | CC..09T3.. | | OBV-TSBS416C | TC..16T3.. | | 16 | 16 | 120 | |
| | OBV-CTBS419 | CC..1204.. | | OBV-TSBS419C | TC..16T3.. | | 19 | 19 | 140 | |
| | OBV-CTBS425 | CC..1204.. | | OBV-TSBS425C | TC..16T3.. | | 25 | 25 | 150 | |
| | | OBV-CTBS906 | CC..0602.. | | OBV-TSBS906C | TC..0902.. | | 6 | 6 | 55 |
| | | OBV-CTBS908 | CC..0602.. | | OBV-TSBS908C | TC..0902.. | | 8 | 8 | 55 |
| | | OBV-CTBS910 | CC..0602.. | | OBV-TSBS910C | TC..0902.. | | 10 | 10 | 65 |
| OBV-CTBS913 | | CC..09T3.. | | OBV-TSBS913C | TC..1102.. | | 13 | 13 | 80 | |
| OBV-CTBS916 | | CC..09T3.. | | OBV-TSBS916C | TC..16T3.. | | 16 | 16 | 120 | |
| | OBV-CTBS919 | CC..1204.. | | OBV-TSBS919C | TC..16T3.. | | 19 | 19 | 140 | |
| | OBV-CTBS925 | CC..1204.. | | OBV-TSBS925C | TC..16T3.. | | 25 | 25 | 150 | |
| | | OBV-CTBS906L | CC..0602.. | | | | | 6 | 6 | 55 |
| | | OBV-CTBS908L | CC..0602.. | | | | | 8 | 8 | 55 |
| | | OBV-CTBS910L | CC..0602.. | | | | | 10 | 10 | 65 |
| OBV-CTBS913L | | CC..09T3.. | | | | | 13 | 13 | 80 | |
| OBV-CTBS916L | | CC..09T3.. | | | | | 16 | 16 | 120 | |
| OBV-CTBS919L | CC..1204.. | | | | | 19 | 19 | 140 | | |
| OBV-CTBS925L | CC..1204.. | | | | | 25 | 25 | 150 | | |

| 刀片型號 Insert | Screw | Wrench |
|-------------|---------|--------|
| | MS2506A | T09 |
| | MS4011A | T15 |
| | MS5011A | T20 |

| 刀片型號 Insert | Screw | Wrench |
|-------------|---------|--------|
| | MS2206A | T07 |
| | MS2504A | T09 |
| | MS4011A | T15 |

小徑搪刀
BORING SHANK

| 刀片形狀 Insert Shape | 產品編號 3 - Item Code | 刀片型號 Insert | 牌價 Price | 產品編號 4 - Item Code | 刀片型號 Insert | 牌價 Price | 尺寸 Dimensions (mm) | | | |
|----------------------|-----------------------|----------------|-------------|-----------------------|----------------|-------------|-----------------------|----|-----|-----|
| | | | | | | | H | W | L | |
| | OBV-SBS306 | TP..0902.. | | | | | 6 | 6 | 55 | |
| | OBV-SBS308 | TP..0902.. | | OBV-SBS308A | TP..0902.. | | 8 | 8 | 55 | |
| | OBV-SBS310 | TP..0902.. | | OBV-SBS310A | TP..0902.. | | 10 | 10 | 65 | |
| | OBV-SBS313 | TP..1103.. | | OBV-SBS313A | TP..1103.. | | 13 | 13 | 80 | |
| | OBV-SBS316 | TP..1103.. | | OBV-SBS316A | TP..1103.. | | 16 | 16 | 120 | |
| | OBV-SBS316B | TP..1603.. | | | | | 16 | 16 | 120 | |
| | OBV-SBS319 | TP..1603.. | | OBV-SBS319A | TP..1603.. | | 19 | 19 | 140 | |
| | OBV-SBS325 | TP..1603.. | | | | | 25 | 25 | 150 | |
| | | OBV-SBS406 | TP..0902.. | | | | | 6 | 6 | 55 |
| | | OBV-SBS408 | TP..0902.. | | OBV-SBS408A | TP..0902.. | | 8 | 8 | 55 |
| | | OBV-SBS410 | TP..0902.. | | OBV-SBS410A | TP..0902.. | | 10 | 10 | 65 |
| | | OBV-SBS413 | TP..1103.. | | OBV-SBS413A | TP..1103.. | | 13 | 13 | 80 |
| OBV-SBS416 | | TP..1103.. | | OBV-SBS416A | TP..1103.. | | 16 | 16 | 120 | |
| OBV-SBS416B | | TP..1603.. | | | | | 16 | 16 | 120 | |
| | OBV-SBS419 | TP..1603.. | | OBV-SBS419A | TP..1603.. | | 19 | 19 | 140 | |
| | OBV-SBS425 | TP..1603.. | | | | | 25 | 25 | 150 | |
| | | OBV-SBS906 | TP..0902.. | | | | | 6 | 6 | 55 |
| | | OBV-SBS908 | TP..0902.. | | OBV-SBS908A | TP..0902.. | | 8 | 8 | 55 |
| | | OBV-SBS910 | TP..0902.. | | OBV-SBS910A | TP..0902.. | | 10 | 10 | 65 |
| | | OBV-SBS913 | TP..1103.. | | OBV-SBS913A | TP..1103.. | | 13 | 13 | 80 |
| OBV-SBS916 | | TP..1103.. | | OBV-SBS916A | TP..1103.. | | 16 | 16 | 120 | |
| OBV-SBS916B | | TP..1603.. | | | | | 16 | 16 | 120 | |
| | OBV-SBS919 | TP..1603.. | | | | | 19 | 19 | 140 | |
| | OBV-SBS925 | TP..1603.. | | | | | 25 | 25 | 150 | |
| | | OBV-SBS916 | TP..1103.. | | | | | 16 | 16 | 150 |
| | | OBV-SBS920 | TP..1103.. | | | | | 20 | 20 | 150 |

| 刀片型號 Insert | Screw | Wrench |
|-------------|---------|--------|
| | MS2506A | T09 |
| | MS3008A | T09 |
| | MS4011A | T15 |

(A) 銑刀
ENDMILLS
(B) 鑽頭
DRILLS
(C) 絞刀
REAMERS
(D) 絲攻
TAPS
(E) 刀桿/刀盤
MILLING CUTTERS
(F) 刀片
INSERTS

(A) 銑刀
ENDMILLS
(B) 鑽頭
DRILLS
(C) 絞刀
REAMERS
(D) 絲攻
TAPS
(E) 刀桿/刀盤
MILLING CUTTERS
(F) 刀片
INSERTS